

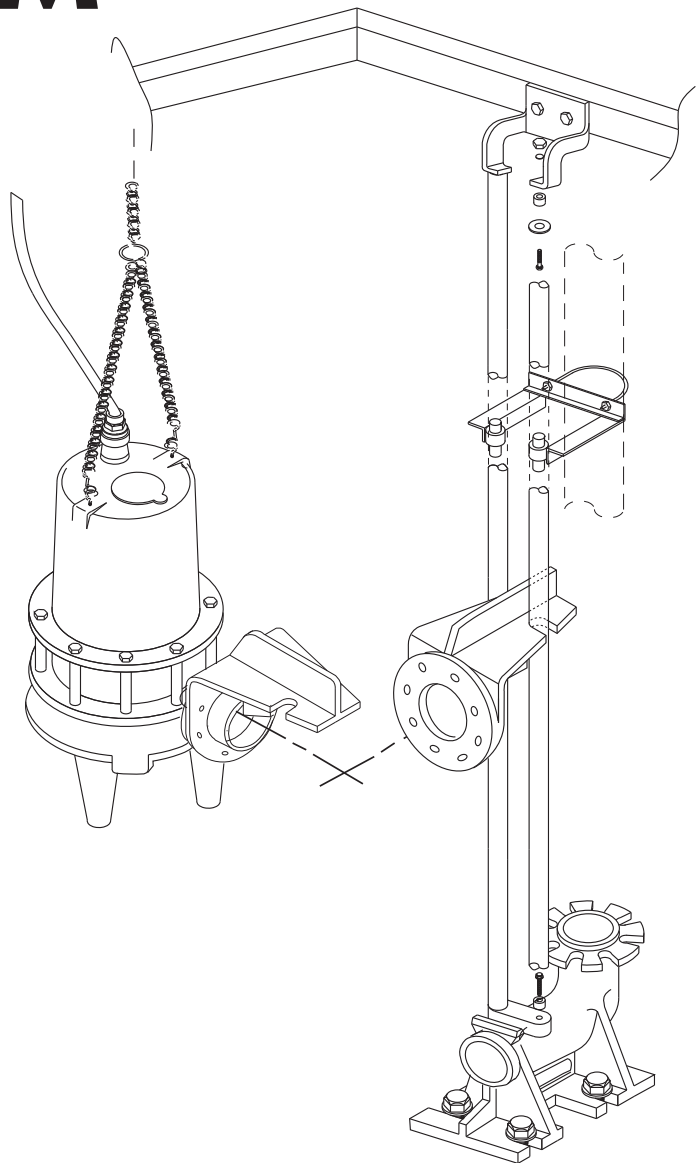

# HYDROMATIC®

## METAL-TO-METAL RAIL SYSTEM



NOTE! To the installer: Please make sure you provide this manual to the owner of the pumping equipment or to the responsible party who maintains the system.

Part # 5625-360-1 Item # E-03-360 07/09



**Pentair  
Water™**

# General Information

Thank you for purchasing your Hydromatic® pump. To help ensure years of trouble-free operation, please read the following manual carefully.

## Before Operation:

Read the following instructions carefully. Reasonable care and safe methods should be practiced. Check local codes and requirements before installation.

## Attention:

This manual contains important information for the safe use of this product. Read this manual completely before using this product and refer to it often for continued safe product use. **DO NOT THROW AWAY OR LOSE THIS MANUAL.** Keep it in a safe place so that you may refer to it often.

## Unpacking Pump:

Remove pump from carton. When unpacking unit, check for concealed damage. Claims for damage must be made at the receiving end through the delivery carrier. Damage cannot be processed from the factory.

**WARNING: Before handling these pumps and controls, always disconnect the power first. Do not smoke or use sparkable electrical devices or flames in a septic (gaseous) or possible septic sump.**

## System Description:

In a Hydromatic Metal-to-Metal (MTM) Rail System, the pump is raised and lowered in the basin on pipe rails.

A hydraulic sealing flange at the pump discharge allows the pump to be connected and removed from the discharge elbow with ease at any time, without entering the wet well. There is no need to disconnect any piping or electrical connections to remove a pump for inspection or routine maintenance checks. A typical system will operate on float control switches. A bottom float control will turn off the pump(s). An additional float control per pump is then used to turn on the pump(s). In a multiple pump station, the pumps are automatically alternated if using a standard Hydromatic panel. Also, additional float controls may be used to indicate high and/or low water sump conditions. The general equipment for a simplex and duplex system includes the following:

Simplex	Duplex
One pump	Two pumps
One discharge elbow assembly	Two discharge elbow assemblies
One hydraulic sealing flange	Two hydraulic sealing flanges
Two guide rails	Four guide rails
One lifting chain	Two lifting chains
One door & frame assembly	Two door & frame assemblies
Electrical controls	Electrical controls
Two level controls	Three level controls

## Pumps Not Operating or in Storage:

Pumps with carbon ceramic seals must have impellers manually

rotated (6 revolutions) after setting non-operational for 3 months or longer and prior to electrical start-up.

Pumps with tungsten carbide seals must have impellers manually rotated (6 revolutions) after setting non-operational for 3 weeks or longer and prior to electrical start-up.

## Codes:

All codes must be observed. Consult with the local inspector before installation to avoid costly delays. Hydromatic is not responsible for any expense incurred to meet local codes.

# Pump Installation

## 1. Concrete Basin(s):

Pour one or two concrete systems (one for pumps and control, etc. and one for valves, if required) or obtain precast concrete rings. A 45 degree slope may be poured around the inside perimeter of the basin at the bottom to prevent solids buildup providing the slope does not interfere with the discharge elbow and pump locations. Before beginning the installation, refer to the "Installation Data" as found in the Hydromatic Engineered Products Catalog.

Follow the Installation Data taking into account the location of the discharge pipe, inlet pipe, controls, vent pipe, and the anchoring requirements of the discharge elbow(s). (All of the above concrete work by others.)

## 2. Discharge Elbow Installation:

See "Installation Data" for the proper location of the discharge elbow on the basin bottom. Either

cast anchor bolts into basin bottom protruding 2" from basin floor with lockwashers and nuts securing, or drill holes for expansion lag screws to secure elbow to basin bottom. Each elbow requires four anchors (all furnished by others). Each elbow must be level. Length of anchors embedded in concrete varies with materials used, but must be sufficient to withstand the weight, torque, and thrust loads imposed by the pump. See "Instructions for Assembly" (Page 7) for an illustration of the discharge elbow.

### **3. Discharge Piping (All Supplied by Others):**

Install vertical discharge piping modules to elbow using bolts, nuts, lockwashers and gasket. Install remainder of the sump discharge piping. This typically includes a vertical run of piping appropriately sized and configured to mate with the vertical discharge piping, a ninety degree elbow, and a horizontal run of piping approximately sized and configured to mate with the valve box or main piping. Install horizontal run extending through the wall of basin. Secure vertical run to the vertical discharge piping using the appropriate method (i.e., flange, weld, gasketed collar coupling) and grout all piping extending through basin walls.

**NOTE: If using flanged connections be certain that adequate clearances are provided throughout for installation of bolts, nuts, lockwashers, and gaskets.**

If total run of vertical piping exceeds twelve (12) feet, install a piping brace at the approximate midpoint of the piping. Secure

brace (i.e., U-bolt with angle iron strap and angle iron extensions) to both piping and wall of basin.

### **4. Basin Cover(s):**

The basin cover for the sump and valve box can either be poured concrete or precast. If Hydromatic door and frame assemblies are used, locate the concrete openings with respect to the discharge elbow mounting studs as shown in the installation data. If the covers are poured, place the door and frame assembly inside the concrete form and position per installation data. Anchor straps are provided on the door frames to secure them to the concrete. If precast covers are used, remove anchor straps from frame before installing into covers. Either cast four 3/8" anchor bolts into the top of the precast cover or drill holes for expansion lag screws. Use either 3/8" nuts or stainless steel bolts to secure door and frame assembly to cover. If valves are to be inside the wet well, provide accessways as required for the piping and valves to access piping shutoff valves (see Installation data for general dimensions of accessways). Accessways must be covered and secured with tamper-proof hardware (by others).

### **5. Guide Rail Installation:**

Install the guide rails by attaching the lower end of the guide rail to the plugs on the topside of the discharge elbow. See Page 7 for an illustration of the MTM guide rail mounted to the discharge elbow. At the top of the guide rails, plumb and then fasten the guide rail to the door and frame assembly via the upper guide rail bracket.

### **6. Intermediate Guide Rail Bracing:**

Sump depths of 15' 0" and greater require intermediate guide rail bracing. The braces mount on the vertical discharge pipes with U-bolts which are sized according to the discharge pipe size. The number of guide rail braces required are as follows:

#### **Sump Depths:**

15' 0"–30' 0" – 1 Guide rail brace required  
30' 0"–45' 0" – 2 Guide rail braces required

### **7. Exterior Piping:**

Install the inlet hub(s) in the side of basin and install inlet piping in the hub and grout, or install inlet pipe(s) directly into basin and grout. Install drain pipe from valve box (if required) to basin. Slope pipe to give proper drainage to basin. Install vent piping in side of basin (if required). Extend piping to a proper elevation above grade (as required by plans and specifications and/or local codes). All piping furnished by others. See Installation Data for typical piping arrangement.

### **8. Pump and Sealing Flange:**

Assemble the Sealing Flange to the pump discharge flange using a gasket between the two. See Page 7 and follow illustration.

### **9. Pump Installation:**

Check all piping braces and supports for proper installation and tightness.

Attach one end of the lifting cable or chain to the pump eyebolts and the other to a hook supplied on the inside of the hatch frame.

# Pump Installation

Lower the pump into the basin locating rail guide between the two guide rails. Attach the upper end of lifting assembly to the hook provided on the inside of the Hydromatic door and frame.

## 10. Float Switches:

Mount the float switch mounting bracket to the door and frame assembly using  $\frac{3}{8}$  - 16 stainless steel screws. Include a dielectric gasket (by others) between dissimilar metals to avoid galvanic corrosion. Allow excess float cable to loop over mounting bracket. The sump level is controlled by Hydromatic float switch controls. The float is held in position in the sump by a weight attached to the power cord above the float. The cord supports the float and is adjusted for height from the surface. Duplex systems use three controls: one at both pumps off, one set at one pump on, and one set for both pumps on. Pumps alternate operation on each successive cycle with a Hydromatic Q-Panel. The alarm level is usually set above the override level as it is possible for one pump to fail and the other to operate on the override level with the sump level never reaching the alarm level. Do not let floats rest against basin wall or bottom, or entangle with each other or pump(s).

## 11A. Q-Panel on Mounting Stand:

When the Q-Panel mounting stand is used, either cast four  $\frac{1}{2}$ " anchor bolts into the concrete cover, or drill holes for expansion lag screws and attach stand (bolts

or lag screws furnished by others). Insert power and sensor cords from the pumps and all float cords through the bushing into the sump cover. Bolt the panel to the panel stand. (Nuts, bolts, and washers are not supplied.) Make connections between the bottom of the control panel and the basin cover using flexible conduit and conduit seals (by others). When installing pump power cords, make certain that the cords do not rub against the pump or bottom of the basin. Shorten cords to suit the installation. See Bulletin Q-701 for the "Installation and Service Manual" on the electrical Q-Panel system.

## 11B. Q-Panel Mounted Remote from Basin:

If the Q-Panel is remotely located, instead of on the mounting stand

at the basin, install coupling through basin wall. Screw protective bushing from inside basin into coupling (all furnished by others). Make connections outside station using wiring, conduit seals (potted) and conduit to remotely located Q-Panel (conduit and seals not furnished). Insert the power and sensor cords through the coupling provided with the bushing. Grout in coupling goes through sump wall (by others). When installing pump power cords, make certain that cords do not rub against pump or on bottom of basin. Shorten cords to suit the installation. See Bulletin Q-701 for the "Installation and Service Manual" on the electric Q-Panel system.

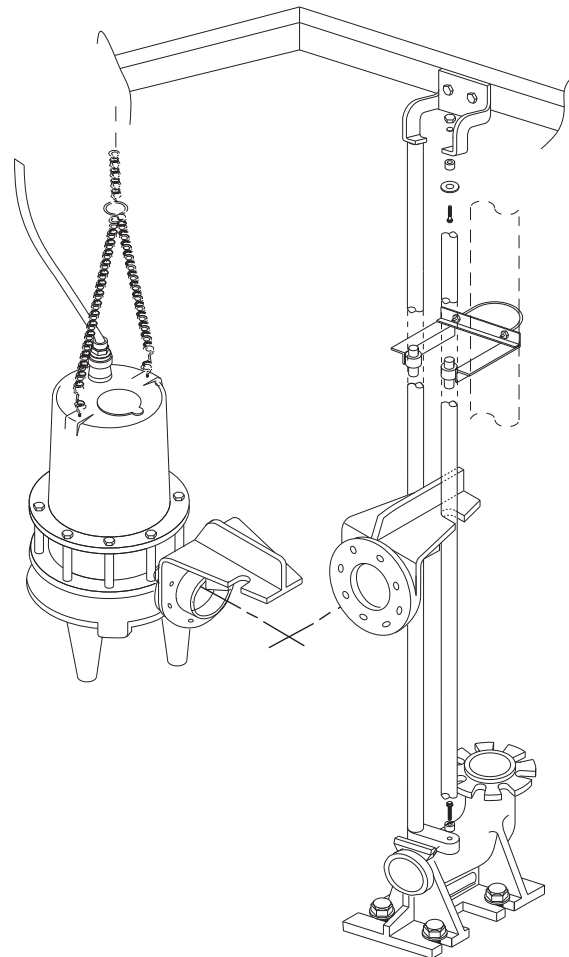

## Pump Operations

**WARNING:** Before handling these pumps and controls, always disconnect the power first. Do not smoke or use sparkable electrical devices or flames in a septic (gaseous) or possible septic basin.

See Pump Installation and Service Manual for submersible pump operation on starting system.

Clean all trash and sticks from basin and connect pump to piping.

## Pump Maintenance

**Removing Pump from Basin for Servicing:**

**WARNING:** Before handling these pumps and controls, always disconnect the power first. Do not smoke or use sparkable electrical devices or flames in a septic (gaseous) or possible septic basin.

To remove a pump from a standard installation (control panel mounted on basin cover), the power to the control panel is first turned off. Close the plug valve. Disconnect the power cords and sensor cords in the control panel from their terminals. Lift out the pump from the basin by means of the chain or cable. Disconnect the flexible conduit, power and sensor cords from the control panel. Pull the pump cord down through the pipe coupling while holding the cord on the underside of the basin cover so the cords do not fall into the basin.

For reinstalling the pump, reverse the above procedure.

**Removing Float Controls for Replacement:**

To remove a float for replacement from a standard installation (control panel mounted on basin cover), the power is first turned off to the control panel. Disconnect the float leads from the terminals in the control panel. Disconnect the flexible conduit from the control panel. Remove the flexible conduit and the float control leads from the control panel. Pull the pump cord through the pipe coupling while holding

the cords on the underside of the basin cover so the cords do not fall into the basin. Remove flexible conduit from potting head. Break out potting from the potting head and remove the float wire. Remove float cord from the float cord mounting bracket and remove float from basin. Replace 3900 float by reversing removal procedure. Repot the leads in the potting head according to N.E.C. and/or local codes.

For the removal of the pumps and float controls from systems with the control panel mounted remote from basin cover, see the Pump Installation and Service Manual.

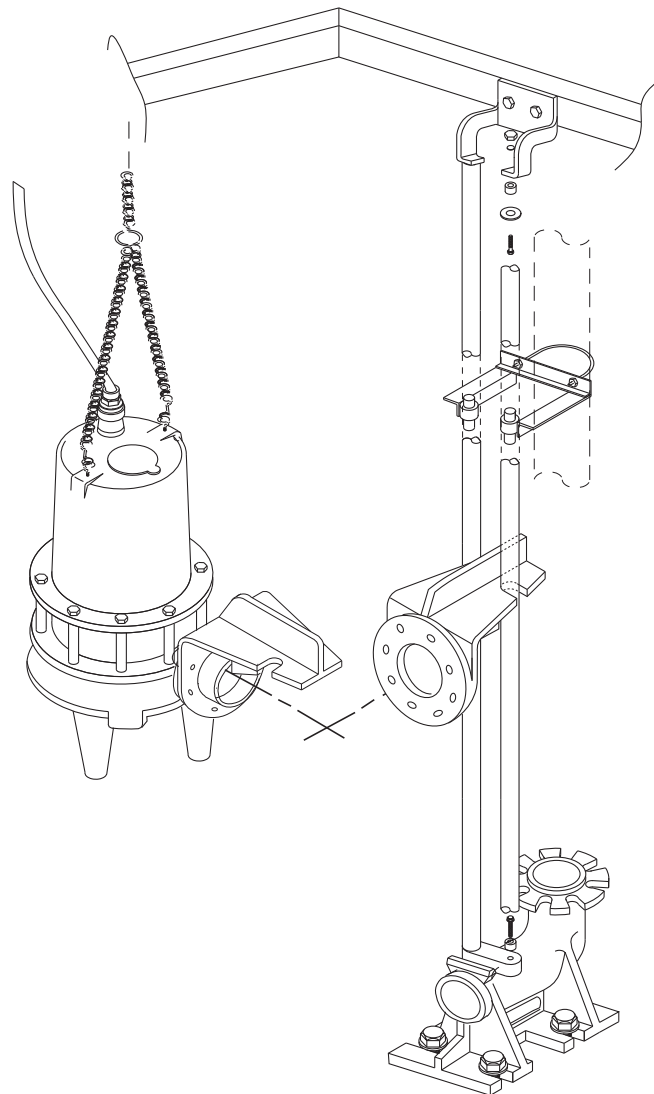



# Pump Troubleshooting

**WARNING: Before handling these pumps and controls, always disconnect the power first. Do not smoke or use sparkable electrical devices or flames in a septic (gaseous) or possible septic basin.**

The following is a list of common problems and possible solutions. Refer to Pump Installation and Service Manual for any necessary adjusting, dismantling or repair work required on the pump.

For Control Panel troubleshooting chart, refer to Control Panel Installation and Service Manual Q-701.

**Pump runs but does not pump down the basin with the selector switch on either Hand or Automatic position.**

1. Impeller may be clogged. Amperage higher than nameplate will indicate this.
2. Pump rotation may be wrong. Reversing any two line leads on three phase pumps will reverse the rotation.
3. Discharge plug valve may be closed.
4. Plugging anywhere from impeller to sealing flange. This is evident if no water runs out of sealing flange after raising the pump. Pull the pump from the basin to find the clog.
5. Plugging beyond the sealing flange. This is evident if water does run out when pump is operating when disconnecting the sealing flange from the discharge elbow. Remove the check valve, clean out cover

and plug valve and other piping, if necessary, inside valve box to find clog. Reassemble all valves and piping. If the basin is still not pumped down after the pump is lowered again and the sealing flange is reconnected, proceed in a logical manner to locate and clear the plugging.

6. Discharge head may be too high. Check elevation against design point of pump.
7. Improper discharge flow. Check for correct impeller size and proper voltage.
8. Check for possible broken or clogged forced main.

**Basin level is pumped down with selector switch on Hand position, but is not pumped down with selector switch on Automatic position.**

1. Floats are not hanging free in the basin or are covered with debris. Pump the level down with the selector switch on Hand, so that the floats can be observed. Relocate and clean all floats as necessary.
2. If this is a new installation and original start-up, the floats may be miswired into the control panel. Recheck the wiring diagrams and schematics in the panel. If the start and stop floats are hooked in reverse, the pump will short cycle on and off and will not pump the level down.
3. Floats or alternator are malfunctioning. Pull the floats out of the basin, clean them and lay them on the ground. Lift up the stop (lower) float in the left hand, the start (upper) float in the right hand and with the bulbs hanging free, turn selector switch to Automatic. Lower the left

hand until the float hits the ground and lies on its side. Nothing should happen. After lowering the right hand in the same manner, the pump should start. When raising the right hand to suspend the float, the pump should continue to run. The pump should stop when raising the left hand to suspend the float. If this procedure does not cause the pump to operate as described, either order new float switches or replace alternator relay.

# M-T-M Rail System

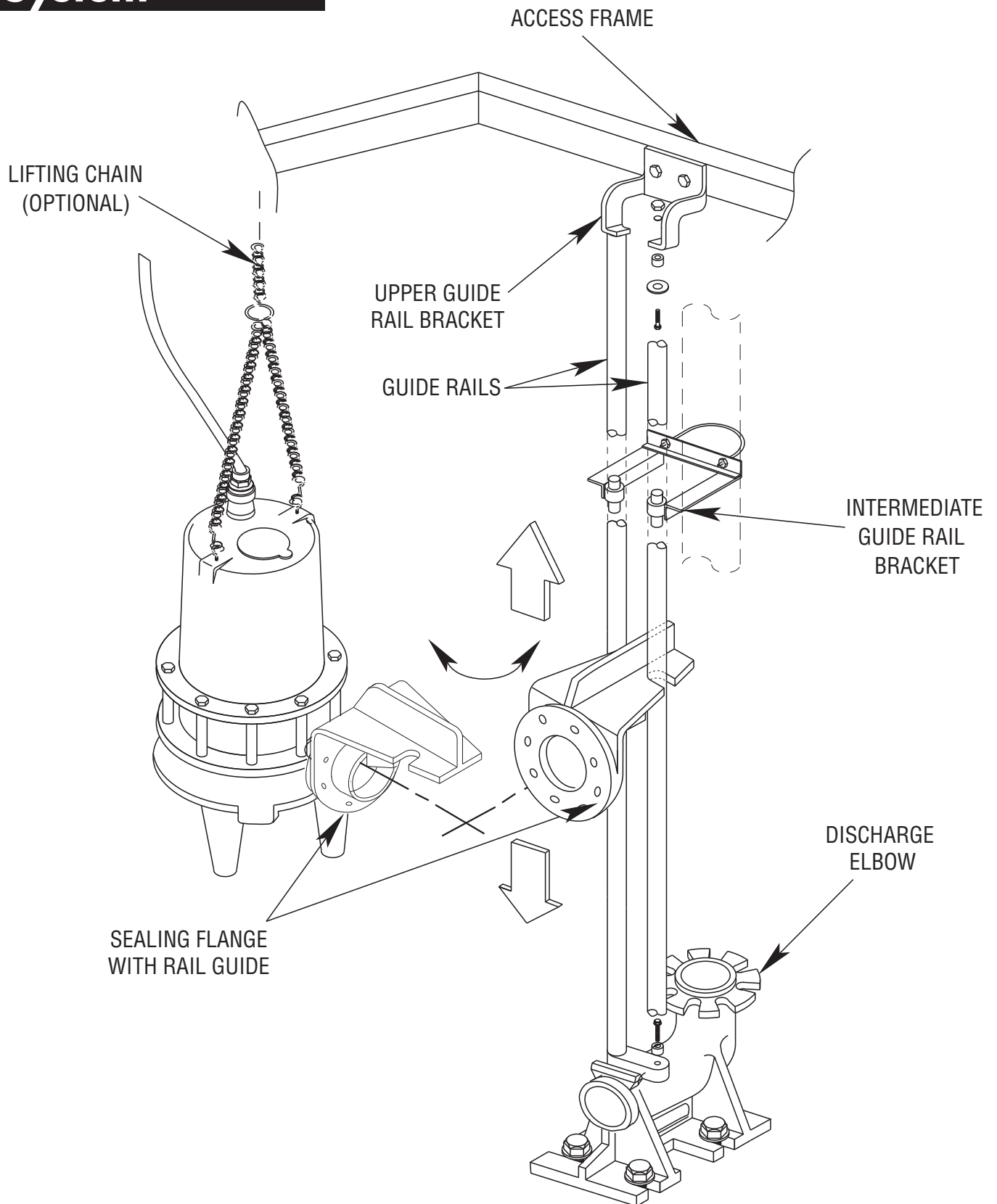

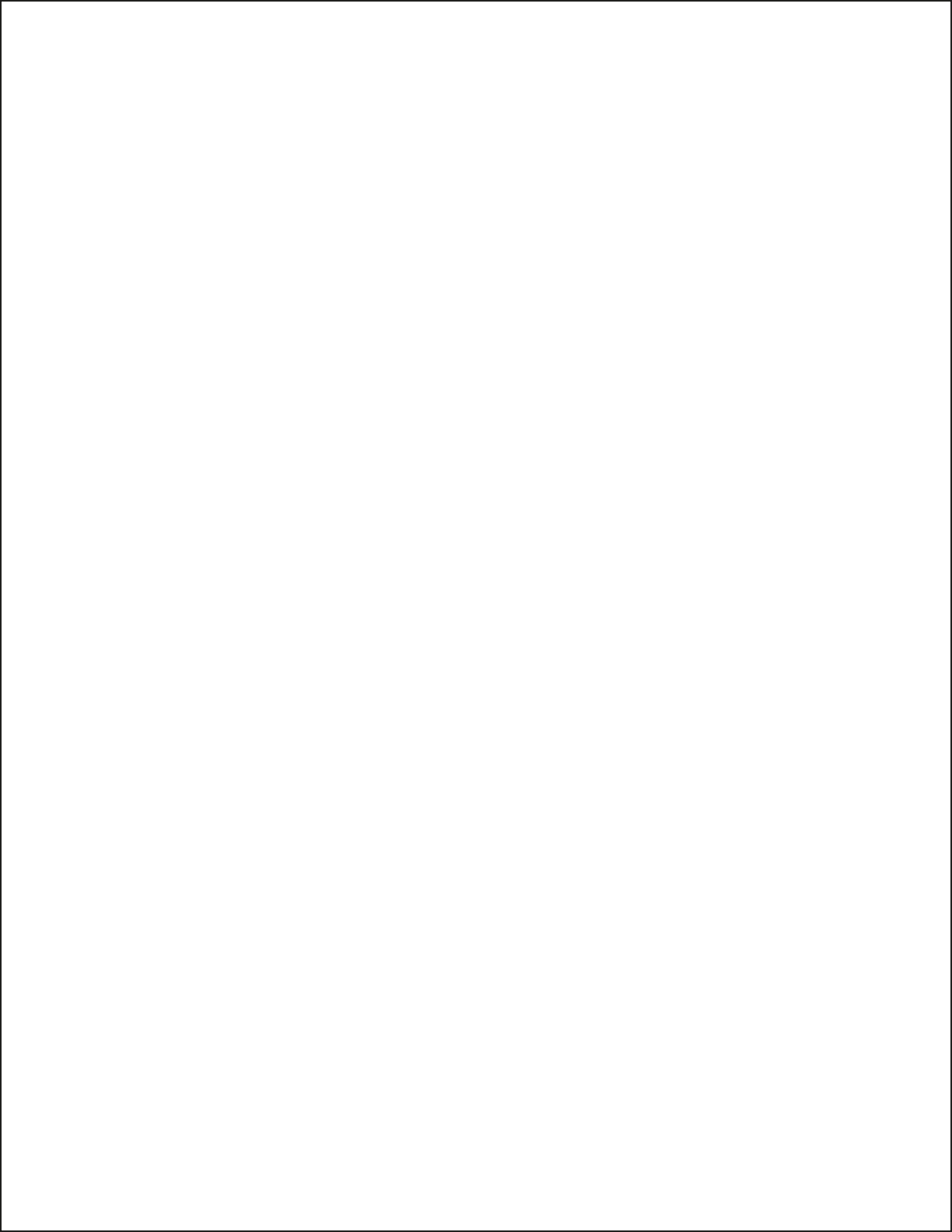



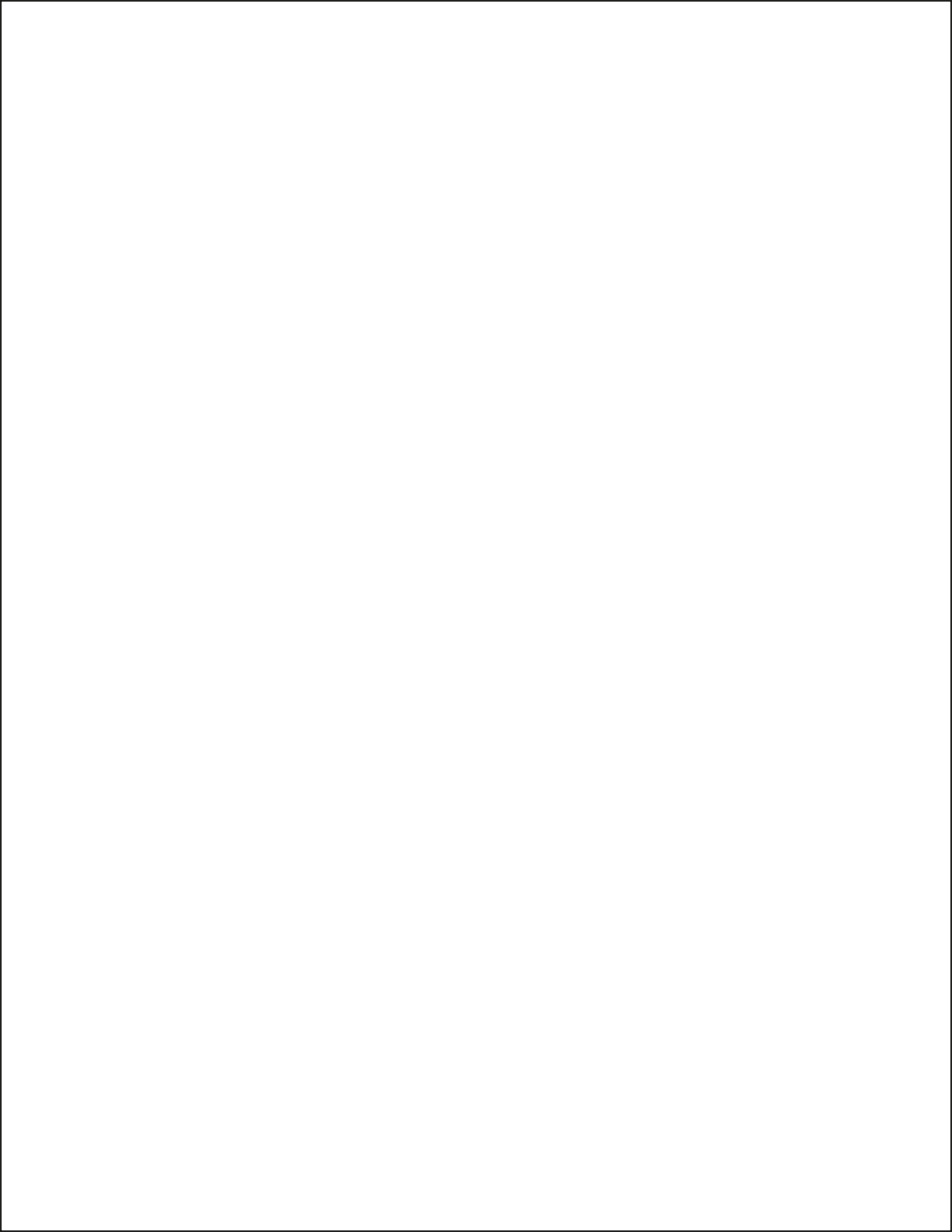

# STANDARD LIMITED WARRANTY

**HYDROMATIC®** warrants its products against defects in material and workmanship for a period of 12 months from the date of shipment from Hydromatic or 18 months from the manufacturing date, whichever occurs first - provided that such products are used in compliance with the requirements of the Hydromatic catalog and technical manuals for use in pumping raw sewage, municipal wastewater or similar, abrasive free non-corrosive liquids.

During the warranty period and subject to the conditions set forth, Hydromatic, at its discretion, will repair or replace to the original user, the parts which prove defective in materials and workmanship. Hydromatic reserves the right to change or improve its products or any portions thereof without being obligated to provide such a change or improvement for prior sold and/or shipped units.

**Start-up reports and electrical schematics** may be required to support warranty claims. Warranty is effective only if Hydromatic authorized control panels are used. All seal fail and heat sensing devices must be hooked up, functional and monitored or this warranty will be void. Hydromatic will only cover the lower seal and labor thereof for all dual seal pumps. Under no circumstance will Hydromatic be responsible for the cost of field labor, travel expenses, rented equipment, removal/reinstallation costs or freight expenses to and from the factory or an authorized Hydromatic service facility.

**This limited warranty will not apply:** (a) to defects or malfunctions resulting from failure to properly install, operate or maintain the unit in accordance with the printed instructions provided; (b) to failures resulting from abuse, accident or negligence; (c) to normal maintenance services and parts used in connection with such service; (d) to units which are not installed in accordance with applicable local codes, ordinances and good trade practices; (e) if the unit is moved from its original installation location; (f) if unit is used for purposes other than for what it is designed and manufactured; (g) to any unit which has been repaired or altered by anyone other than Hydromatic or an authorized Hydromatic service provider; (h) to any unit which has been repaired using non factory specified/OEM parts.

**Warranty Exclusions:** HYDROMATIC MAKES NO EXPRESS OR IMPLIED WARRANTIES WHICH EXTEND BEYOND THE DESCRIPTION ON THE FACE HEREOF. HYDROMATIC SPECIFICALLY DISCLAIMS THE IMPLIED WARRANTIES OF MERCHANTABILITY AND FITNESS FOR ANY PARTICULAR PURPOSE.

**Liability Limitation:** IN NO EVENT SHALL HYDROMATIC BE LIABLE OR RESPONSIBLE FOR CONSEQUENTIAL, INCIDENTAL OR SPECIAL DAMAGES RESULTING FROM OR RELATED IN ANY MANNER TO ANY HYDROMATIC PRODUCT OR PARTS THEREOF. PERSONAL INJURY AND/OR PROPERTY DAMAGE MAY RESULT FROM IMPROPER INSTALLATION. HYDROMATIC DISCLAIMS ALL LIABILITY, INCLUDING LIABILITY UNDER THIS WARRANTY, FOR IMPROPER INSTALLATION. HYDROMATIC RECOMMENDS INSTALLATION BY PROFESSIONALS.

Some states do not permit some or all of the above warranty limitations or the exclusion or limitation of incidental or consequential damages and therefore such limitations may not apply to you. No warranties or representations at any time made by any representatives of Hydromatic shall vary or expand the provision hereof.

 <b>HYDROMATIC®</b>	– Your Authorized Local Distributor –
<p><b>USA</b> 740 East 9th Street, Ashland, Ohio 44805 Tel: 419-289-3042 Fax: 419-281-4087</p>	<p><b>CANADA</b> 269 Trillium Drive, Kitchener, Ontario, Canada N2G 4W5 Tel: 519-896-2163 Fax: 519-896-6337</p>
<a href="http://www.hydromatic.com">www.hydromatic.com</a>	

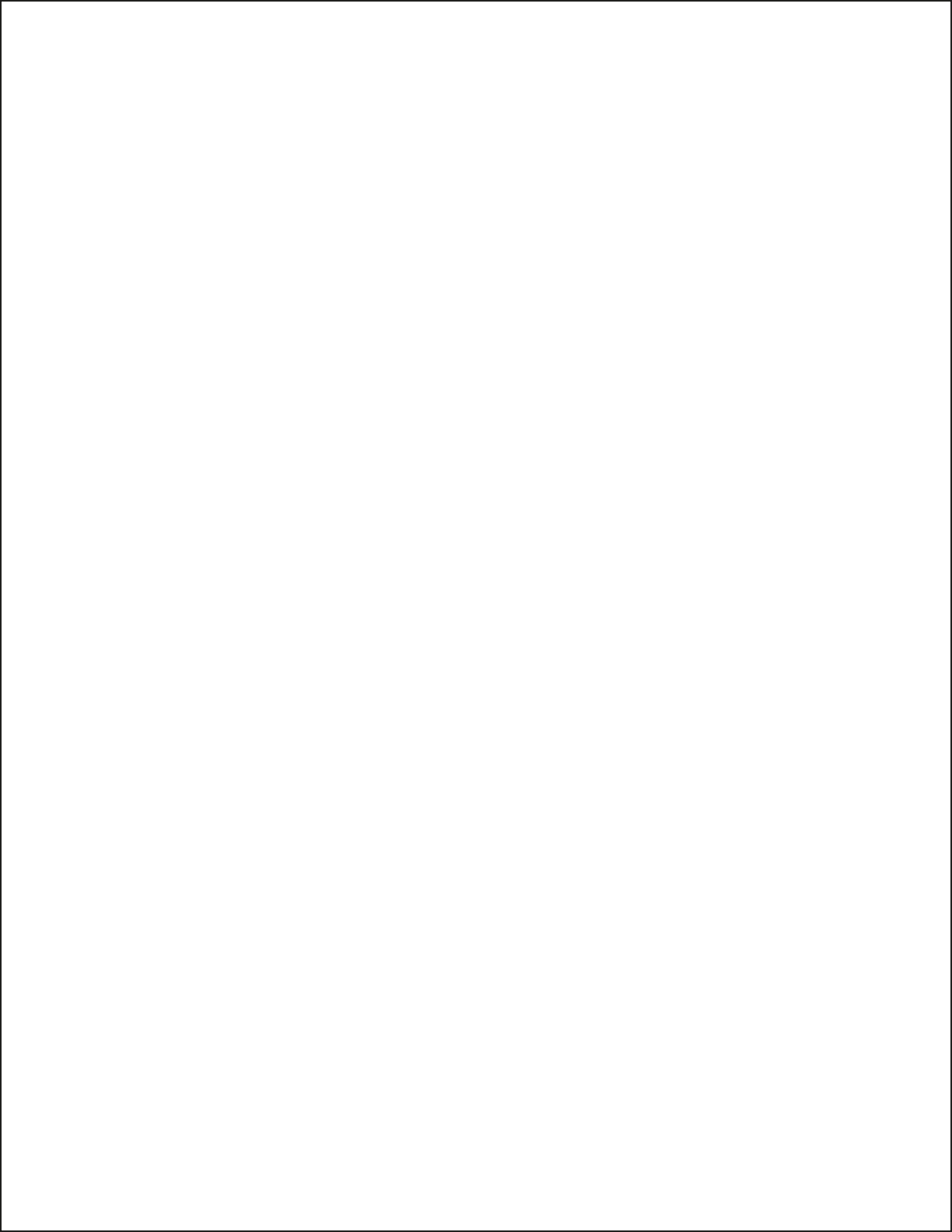

Distributor: \_\_\_\_\_ Order No.: \_\_\_\_\_  
Installing Contractor: \_\_\_\_\_ Phone: \_\_\_\_\_  
Sales Contact: \_\_\_\_\_ Phone: \_\_\_\_\_  
Customer: \_\_\_\_\_  
Location: \_\_\_\_\_

## 1. SYSTEM INFORMATION

Size of Wet Well: \_\_\_\_\_ Manufacturer: \_\_\_\_\_  
Discharge from Bottom of Basin: \_\_\_\_\_ Discharge Location: \_\_\_\_\_  
Inlet from Bottom of Basin: \_\_\_\_\_ Inlet Location: \_\_\_\_\_  
Type of Check Valves: \_\_\_\_\_ Type of Piping: \_\_\_\_\_  
Does System Have Suction Gauges?  Yes  No Suction Pressure Reading: \_\_\_\_\_  
Does System Have Discharge Gauges?  Yes  No Discharge Pressure Reading: \_\_\_\_\_  
Liquid Being Pumped: \_\_\_\_\_ Temperature (F°): \_\_\_\_\_ Pct. of Solid (%): \_\_\_\_\_  
Is a Sketch or Photograph of System Available?  Yes  No *If So, Please Attach.*  
Any Additional Comments on System: \_\_\_\_\_  
\_\_\_\_\_

## 2. ELECTRICAL INFORMATION

Control Panel Part Number: \_\_\_\_\_ Panel Rated Amps: \_\_\_\_\_  
Manufacturer: \_\_\_\_\_ Voltage: \_\_\_\_\_ Phase: \_\_\_\_\_  
Heater Size: \_\_\_\_\_ Location of Panel to Wet Well: \_\_\_\_\_  
Incoming Line Voltage: \_\_\_\_\_ Actual? \_\_\_\_\_  
Voltage to Pumps: \_\_\_\_\_ Actual? \_\_\_\_\_  
Type of Junction Box: \_\_\_\_\_ Manufacturer of Junction Box: \_\_\_\_\_  
Are Floats Installed in Wet Well?  Yes  No Are Floats Set to Engineer's Specs?  Yes  No  
Are Floats Wired for Proper Sequencing?  Yes  No Are Heat Sensors Hooked Up?  Yes  No  
Is the Seal Leak Detection Hooked Up?  Yes  No  
Any Additional Comments on Electrical: \_\_\_\_\_  
\_\_\_\_\_

## 3. PUMP INFORMATION

Type of Pump: \_\_\_\_\_ Serial Number of Pump: \_\_\_\_\_  
Voltage of Pump: \_\_\_\_\_ Phase: \_\_\_\_\_ RPM: \_\_\_\_\_ Amps: \_\_\_\_\_  
Impeller Size: \_\_\_\_\_ C.O.S. TDH: \_\_\_\_\_ GPM: \_\_\_\_\_  
Voltage Supplied from Panel: \_\_\_\_\_ Actual? \_\_\_\_\_  
Actual Amperage (All Phases): Phase 1 Amps: \_\_\_\_\_ Phase 2 Amps: \_\_\_\_\_ Phase 3 Amps: \_\_\_\_\_  
Define the Rotation of the Pump:  Clockwise  Counterclockwise  
Method Used to Check Rotation:  Viewed from the Top  Viewed from the Bottom  
Any Additional Comments on Pumps: \_\_\_\_\_  
\_\_\_\_\_

## 4. ACKNOWLEDGE

Acknowledge that all information is accurate and proper procedures have been followed.

Customer: \_\_\_\_\_ Date: \_\_\_\_\_  
Start-up Technician: \_\_\_\_\_ Date: \_\_\_\_\_

**Send to Warranty Manager, 1101 Myers Parkway, Ashland, OH 44805  
or Fax to 419-207-3344**

**or email to [startupreport@hydromatic.com](mailto:startupreport@hydromatic.com)**

**or submit online at <http://forms.pentairliterature.com/startupform/startupform.asp?type=h>**