



OWNERS MANUAL

INSTALLATION AND OPERATING INSTRUCTIONS
REPAIR PARTS LIST

Engine Driven High Pressure Pump

Model B1-1/2XQBS-11

Model B1-1/2XQBS-18

Model B1-1/2XQBS-26

CALIFORNIA

Proposition 65 Warning

Diesel engine exhaust and some of its constituents are known to the State of California to cause cancer, birth defects, and other reproductive harm.

IMPORTANT

For best possible performance and continuous, satisfactory operation, read these instructions before installing your new pump.

Should service be required, this manual can be a valuable guide.

It should be kept near the installation for ready reference.

Record nameplate data from pump on blank nameplate inside this manual for future reference.

Berkeley Pumps / 293 Wright Street / Delavan, WI 53115

F00650 (Rev. 4/29/05)

Table of Contents

	Page
• SAFETY	3
• INSTALLATION / OPERATION	4
• MAINTENANCE	5
• DISASSEMBLY / ASSEMBLY	6-8
• REPAIR PARTS.....	9-13

BERKELEY/WICOR CANADA WARRANTY

Berkeley/Wicor Canada, Inc. ("Wicor") warrants to the original consumer purchaser ("Purchaser") of its products that they are free from defects in material or workmanship.

If within twelve (12) months from the date of installation or twenty-four (24) months from the date of manufacture any such product shall prove to be defective, it shall be repaired or replaced at Berkeley's/Wicor's option, subject to the terms and conditions set forth below.

General Terms and Conditions

Purchaser must pay all labor and shipping charges necessary to replace product covered by this warranty. This warranty shall not apply to products which, in the sole judgement of Berkeley/Wicor, have been subject to negligence, abuse, accident, misapplication, tampering, alteration; nor due to improper installation, operation, maintenance or storage; nor to other than normal application, use or service, including but not limited to, operational failures caused by corrosion, rust or other foreign materials in the system, or operation at pressures in excess of recommended maximums.

Requests for service under this warranty shall be made by contacting the installing Berkeley/Wicor dealer as soon as possible after the discovery of any alleged defect. Berkeley/Wicor will subsequently take corrective action as promptly as reasonably possible. No requests for service under this warranty will be accepted if received more than 30 days after the term of the warranty.

The warranty on all three phase submersible motors is void if three-leg overload protection of recommended size is not used.

This warranty sets forth Berkeley's/Wicor's sole obligation and purchaser's exclusive remedy for defective products.

BERKELEY/WICOR SHALL NOT BE LIABLE FOR ANY CONSEQUENTIAL, INCIDENTAL, OR CONTINGENT DAMAGES WHATSOEVER.

THE FOREGOING WARRANTIES ARE EXCLUSIVE AND IN LIEU OF ALL OTHER EXPRESS WARRANTIES. IMPLIED WARRANTIES, INCLUDING BUT NOT LIMITED TO THE IMPLIED WARRANTIES OF MERCHANTABILITY AND FITNESS FOR A PARTICULAR PURPOSE, SHALL NOT EXTEND BEYOND THE DURATION OF THE APPLICABLE EXPRESS WARRANTIES PROVIDED HEREIN.

Some states do not allow the exclusion or limitation of incidental or consequential damages or limitations on how long an implied warranty lasts, so the above limitations or exclusions may not apply to you. This warranty gives you specific legal rights and you may also have other rights which vary from state to state.

In the U.S.: Berkeley, 293 Wright St., Delavan, WI 53115

In Canada: Wicor Canada, Inc., 1800 Courtney Park Drive East, Unit 5-7, Mississauga, Ontario L5T 1W1

Wicor Canada, Inc., 200-E, Rue St-Louis, St-Jean-Sur-Richelieu, Québec J3B 1Y1

Safety First

READ AND FOLLOW SAFETY INSTRUCTIONS!

 **This is the safety alert symbol.** When you see this symbol on your pump or in this manual, look for one of the following signal words and be alert to the potential for personal injury:

 **DANGER** warns about hazards that **will** cause serious personal injury, death or major property damage if ignored.

 **WARNING** warns about hazards that **will** or **can** cause serious personal injury, death or major property damage if ignored.

 **CAUTION** warns about hazards that **will** or **can** cause minor personal injury or property damage if ignored.

The label **NOTICE** indicates special instructions which are important but not related to hazards.

Carefully read and follow all safety instructions in this manual and on pump.

Keep safety labels in good condition.

Replace missing or damaged safety labels.

General Safety

Do not allow pump, piping, or any other system component containing water to freeze. Freezing may damage system, leading to injury or flooding. Allowing pump or system components to freeze will void warranty.

Pump approved liquids only with this pump.

Periodically inspect pump and system components.

Wear safety glasses at all times when working on pumps.

Keep work area clean, uncluttered and properly lighted; store properly all unused tools and equipment.

Keep visitors at a safe distance from the work areas.

Make workshops childproof; use padlocks and master switches; remove starter keys.

Installation / Operation

Installation

The unit is shipped completely assembled and ready for installation. However, before installing, inspect it for shipping damage. If any damage is found, notify carrier immediately.

Hoses

System hoses must be at least as large as pump ports (2" suction, 1-1/2" discharge).

Priming

Without Exhaust Primer: Close discharge valve and fill pump with water to completely cover the eye of the impeller.

With Exhaust Primer (see Figure 1, below):

1. Close Clack Valve (Key No. 1,).
2. Close Bronze Shutoff Valve (Key No. 2).
3. Close valve on discharge side of pump.
4. Start engine.
5. Open Bronze Shutoff Valve (Key No. 2).
6. When water runs out of ejector (Key No. 3), close Bronze Shutoff Valve.
7. Open Clack Valve for normal engine exhaust.
8. Slowly open discharge valve on pump.
9. When shutting down engine, close Clack Valve to protect exhaust primer from weather.

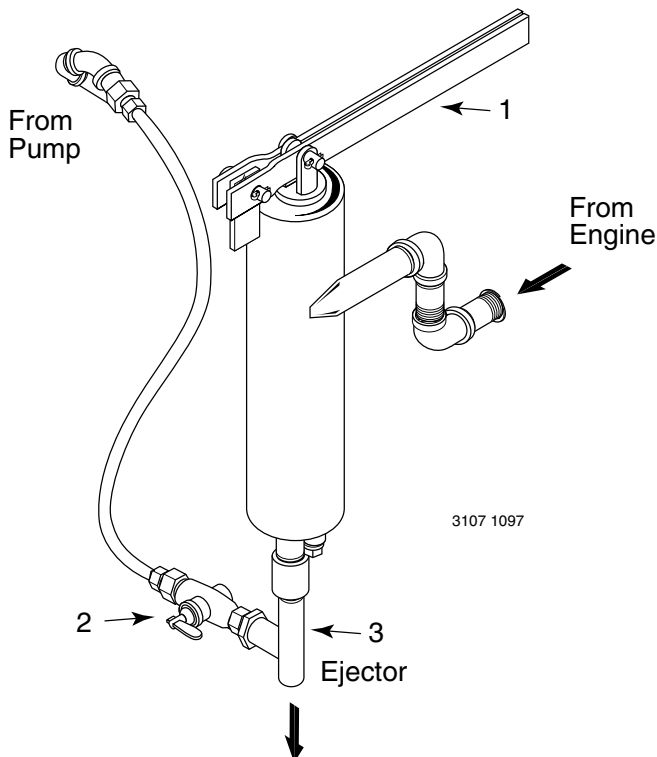

Figure 1

Operation

NOTICE: Never run pump dry for more than a few seconds. Water is required in the case to cool and lubricate the mechanical shaft seal.

Engine Break-in

Follow engine manufacturer's instructions for engine break-in. The pump needs no break-in period.

Engine Speed

The standard engine governor setting may not be adequate for your pumping application. If so, follow engine manufacturer's instructions for adjusting engine operating speed and setting the engine speed control device.

Starting

Start engine with pump discharge valve closed. Follow engine manufacturer's starting instructions. As soon as engine starts, gradually open discharge valve until desired flow rate is reached and set throttle control according to operating conditions.

Stopping

The pump stops when the engine stops. To avoid "dieseling" or "running on", let the engine idle for a few minutes before switching it off.

Continuous Operation

Pressure, flow, and engine speed should not exceed that shown on performance curve for continuous operation. This performance is based on 80% of engine's rated power.

Maintenance

Maintenance

The **pump** does not require any oil or grease for lubrication. The sealed double row ball bearing is lubricated for the life of the bearing.

The **Mechanical Shaft Seal** is lubricated and cooled by the liquid being pumped. **DO NOT RUN DRY**. The seal requires no further maintenance.

The **Engine** should be stopped and the crankcase oil level checked at least once every 8 hours of operation. If necessary, add oil to bring the level up to the Full mark. Follow engine manufacturer's recommendations as to grades of oil to use.

The **Timing Belt** requires no lubrication. It has a fiberglass core, but severe operating conditions may cause it to stretch. Check the timing belt tension with a belt tension tester. The belt tension is correct when applying a midspan 10-lb. load to the belt causes a deflection of 1/4" (see Figure 2).

Check belt tension as follows:

1. Insert tension tester through 1/2" hole in drive case (at belt midspan) until it just touches belt. Record the depth shown on the tester (Figure 2).
2. Depress tension tester until 10 lbs load has been reached and record new depth (Figure 2).
3. The difference between the two readings should be 1/4" when belt tension is correct.
4. If deflection is more than 1/4", tighten belt as follows:
 - A. Loosen (**DO NOT REMOVE**) the nuts on the four studs that hold the pump to the drive case.
 - B. Turn the jackscrew nut clockwise, and retighten the stud nuts.

There is a **wear ring** pressed into the bearing bracket (Models B054728S and B07536S have another one pressed into the diffuser). The radial clearance at the factory is .010" (both sides - .005" per side). When the total clearance increases to .020", replace the wear ring(s).

Belt tension tester:
read belt position
with no deflection

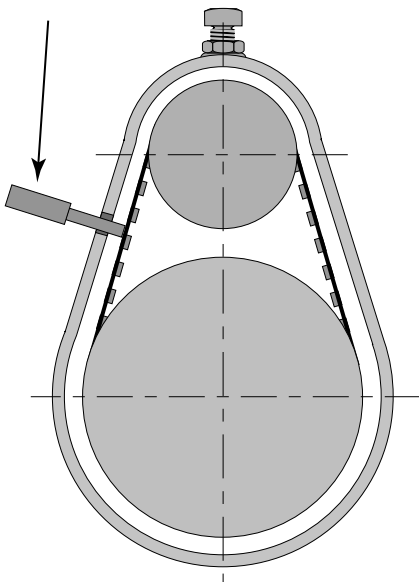

To tighten belt,
turn nut clockwise

Loosen 4 nuts before
making belt adjustment

Belt tension tester:
should read 1/4"
deflection at
10# load.

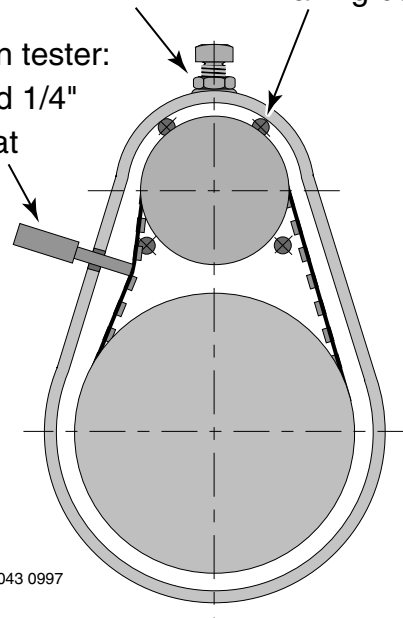

3043 0997

Figure 2: Setting Timing Belt Tension

Disassembly/Assembly

High Pressure Pump Disassembly/Assembly

The complete fire pump consists of the power unit, timing belt drive, and pump assembly. The disassembly/assembly of the pump itself and the timing belt drive will be dealt with here. For instructions concerning disassembly/assembly of the power unit, consult the engine manufacturer or the engine owner's service manual.

The numbers in parenthesis correspond to the Exploded View (Figure 3).

All capscrews and studs must have Loctite AV 10-10 and lockwashers.

Pump Disassembly

1. Disconnect and remove the exhaust primer (if used).
2. Disconnect and remove the seal flush line and fittings (822, 820).

3. Remove the four capscrews holding the pump volute case (1) to the bearing housing (19). Remove the pump volute case.
4. Remove the diffuser (5) and quadding (119A) from the pump volute case.
5. Unscrew the impeller from the pump shaft (turn COUNTER-CLOCKWISE – right-hand thread).
6. Remove the Impeller spacer washer (69) from the shaft.
7. With two screwdrivers, carefully remove the rotating half of the seal (89) from the bearing housing. Be careful not to scratch or mar the shaft.
8. Loosen the three capscrews in the small taper hub (833A) and remove the hub and sprocket from the shaft.
9. Reach into the bearing housing from the sprocket end of the housing with snap ring pliers and remove the internal retaining ring (817).

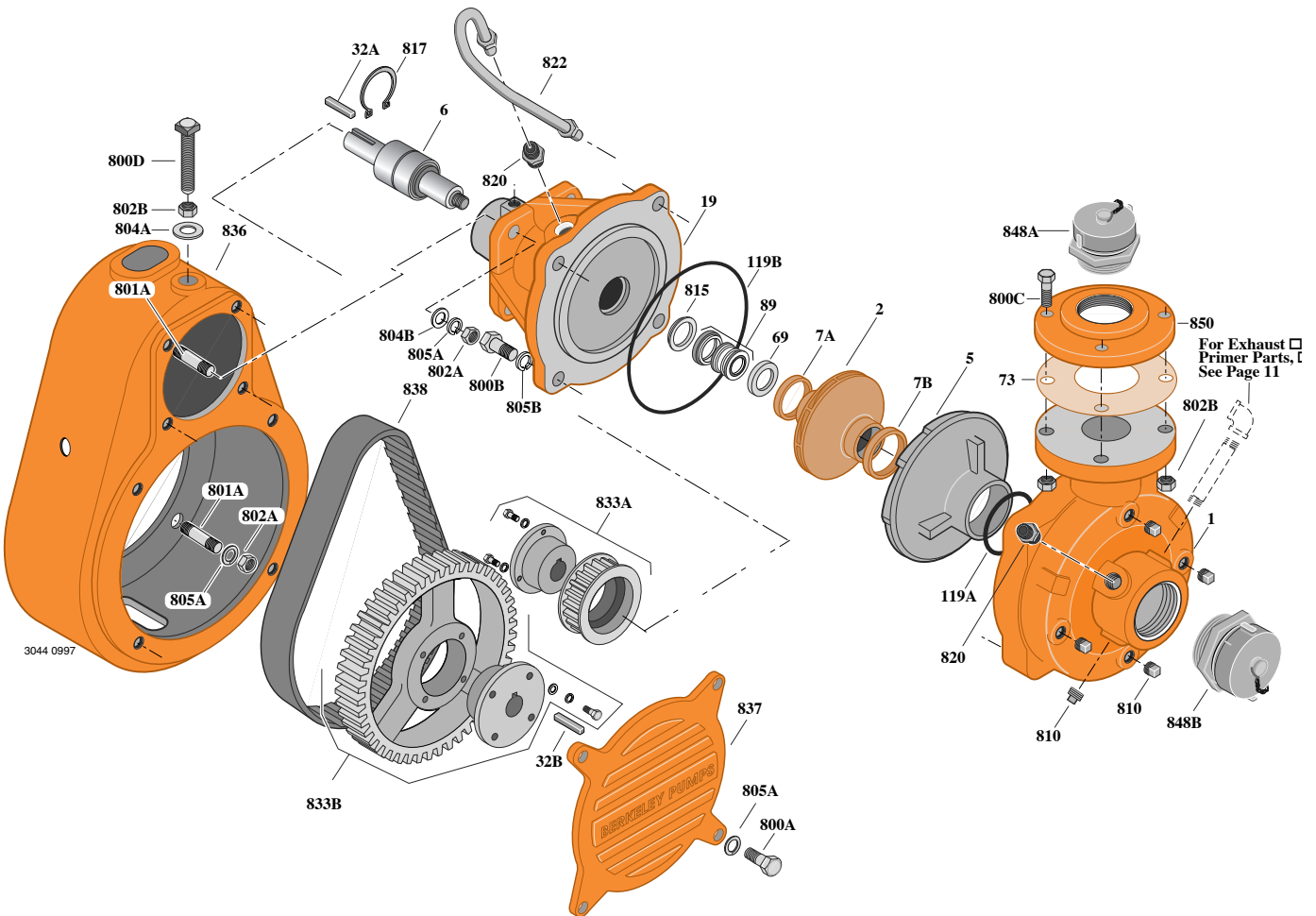

Figure 3: Assembly View

Disassembly/Assembly

10. Tap the shaft and bearing assembly out of the bearing housing from the impeller end of the housing.
NOTICE: Be sure to protect the shaft threads!
11. Check the fit of the wear ring (7 or 7A) to the impeller sleeve (all models) and of the diffuser wear ring (7B) to the impeller hub (Models B054728S and B07536S only). If clearance of either wear ring is more than .020" total (sum of both sides), press out the wear ring(s) and replace it.

Timing Belt Drive Disassembly

1. Disconnect and remove the exhaust primer (if used).
2. Loosen the 1/2" locknut (802B) and remove the jackscrew (800D).
3. Loosen the nuts that hold the pump and bearing housing to the timing belt drive case (836).
4. Slide the pump down to relieve the tension on the timing belt. Remove the nuts and the pump.
5. Remove the cover (837) from the drive case.
6. Remove the three bolts from the taper hub in the large sprocket (the engine shaft sprocket). Remove the hub and sprocket.
7. Remove the timing belt from the case and inspect it closely. Replace it if it shows any signs of deterioration, cracks, breaks, or tears.
8. If you are removing the complete case, remove the nuts from the studs inside the case and remove the case.

Pump Assembly

1. Press the wear ring (7A) into the bearing housing (19).
2. Insert the shaft and bearing unit (6) into the bearing housing (19), making sure that it butts against the inside shoulder. Use Loctite AV 10-10 on the outside diameter of the outer ball bearing race.
3. Install the internal retaining ring (817) in the bearing housing groove.
4. Insert the seal retaining washer (815) in the bearing housing.

5. Lubricate the shaft and the sealing surfaces of the mechanical shaft seal (89) with a soap solution; then slip the seal onto the shaft, rubber drive ring first.
6. Slide the spacer (67) over the shaft thread and locate it against the shaft shoulder.
7. Thread the impeller (2) onto the shaft until it is seated against the shaft shoulder. Check for free rotation and for eye concentricity (eccentricity must not exceed .002" T.I.R.). Use Loctite AV 10-10 on threads.
8. Oil the "O"-Ring (119B) and insert it around the fit of the bearing housing .
9. Install the quadding (119A) around the inside boss of the pump body (1).
10. Press the wear ring (7B - Models B5478S and B07536 only) into the diffuser (2);
11. Install the diffuser in the pump body (1 - all models).
12. Install the pump volute case (1) on the bearing housing and tighten the capscrews.
13. Assemble the shaft key (32A) and small timing belt sprocket (833A) (with the split taper bushing) on the free end of the pump shaft. After making sure that the bushing clears the bearing housing, tighten the three capscrews provided on the taper bushing. Measure and record the distance between the small sprocket and the face of the bearing housing flange (it should be approximately 1-3/16").
14. Install the seal flush line and fittings (820-822) on the pump.
15. Plug the drainage and priming holes with 1/4" NPT plugs (810).
16. Place the gasket (73) (5" O.D. x 1-1/2" I.D. x 1/32") and 1-1/2" NPT x 5" Companion flange (850) on the case discharge and fasten with nuts and bolts.

Timing Belt Drive Assembly

1. Thread the four 7/16" Studs (801B) into the engine bolting face (Models B054728S and B07536S use 3/8" studs, 801A).
2. Install the drive case (836) on the engine crankcase bolting face and tighten the four 7/16" nuts (802C) or 3/8" nuts (802A).
3. Install the four 3/8" studs (801A) in the drive case face to which pump will be attached.

Disassembly/Assembly

Exhaust Primer Assembly

1. Assemble the canister (3), clack (2), and clack lever (1) using the clevis pins (18,20) and cotter pins (19).
2. Install the pipe plug (8) in the bottom of the canister.
3. Assemble the exhaust piping (Model B06160 – 4,5; Model B06591 – 4,5,6,7) on the engine exhaust port. Tighten all components into the position required except the last elbow. Tighten the last elbow snug, making sure that it can be adjusted to accommodate the canister location.
4. Attach the canister assembly to the exhaust piping, tightening the canister connection and the last elbow of the exhaust piping.
5. Attach the coupling (9A) or bushing (9B) and ejector (10A or 10B) to the bottom of the canister. Make sure that the ejector connection is pointed toward the pump.
6. Thread the adapter (11 – Model B06591 only), valve (12), and compression fitting (13) onto the ejector canister assembly.
7. Assemble the pump piping (15,16,17) and the second compression fitting (13) to the pump suction, making sure that the compression fitting (13) is pointed toward the ejector canister assembly.
8. Carefully bend and cut the copper tubing to make the connection between the ejector canister assembly connector and the pump piping connector.
9. Place fittings over each end of the copper tubing, install the tubing, and tighten the compression fittings.

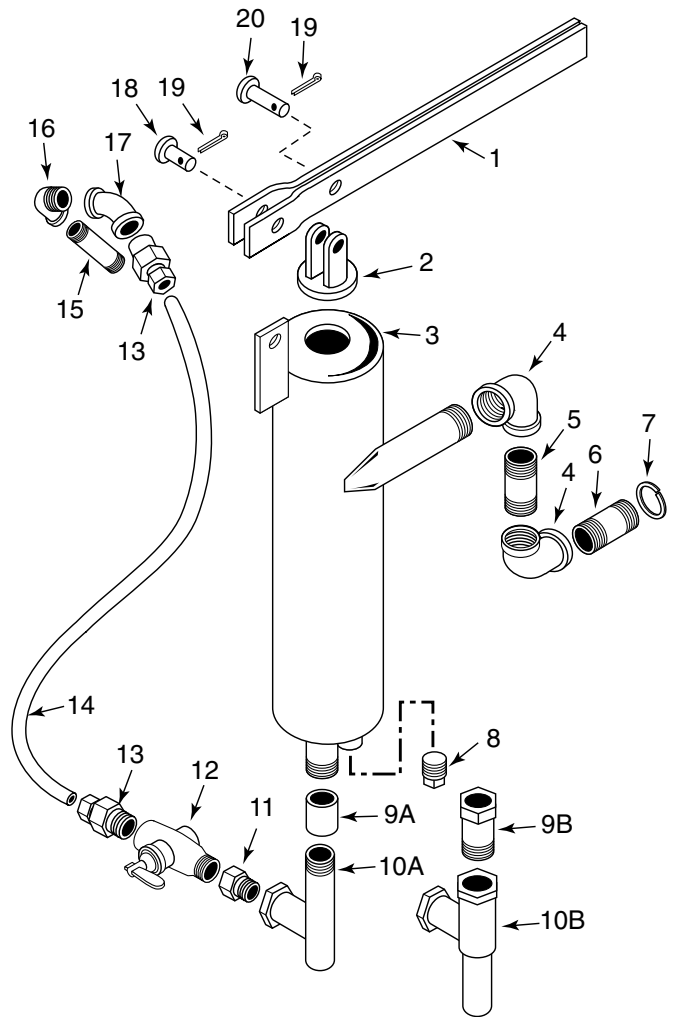
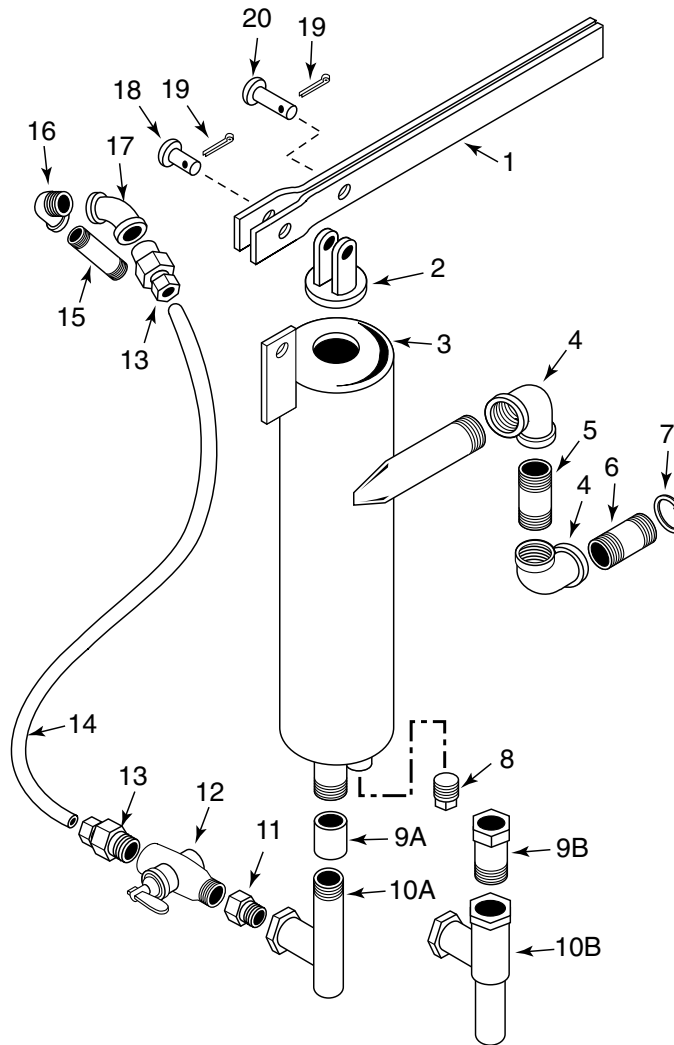

Figure 4: Exhaust Primer Assembly View

Repair Parts – Exhaust Primer



Key No.	Part Description	Qty.	Model	
			B06160	B06591
1	Clack Lever	1	M05224	M05224
2	Clack	1	S14092	S15815
3	Primer Canister	1	H02303	H02735
4	1" FPT Galv. Iron 90° Str El	2	S25381	–
4	1-1/4" FPT Galv. Iron Str El	1	–	S25382
5	1" NPT x 2-1/2" Pipe Nipple	1	S22967	–
5	1-1/4" NPT x 2" Pipe Nipple	1	–	S35058
6	1" NPT x 3-1/2" Pipe Nipple	1	S34721	–
7	1" x 13/16" Conduit Locknut	1	S27573	–
8	1/2" NPT Pipe Plug	1	S23717	S23717
9A	1/2" NPT Pipe Coupling	1	S24264	–
9B	3/4 MPT x 1/2 FPT Galv. Steel Bushing	1	–	S24606
10A	Ejector	1	S14332	–
10B	Ejector	1	–	S15817
11	3/8 MPT x 1/4 Galv. Steel Bushing	1	–	S24601
12	1/4 FPT x 1/4 MPT Bronze Shutoff Valve	1	S34720	S34720
13	3/8" Male Compression Fitting	2	S24017	S24017
14	3/8" Copper Tubing	1	S22480	S22480
15	1/4" NPT x 3-1/2" Tube Steel Nipple	1	S27136	S27136
16	1/4 FPT Galv. Iron 90° Str El	1	S25377	S25377
17	1/4 FPT Galv. Iron 45° Str El	1	S25422	S25392
18	1/4" x 3/4" Clevis Pin	1	S28075	S28075
19	1/16" x 1/2" Cotter Pin	2	S26606	S26606
20	1/4" x 1" Clevis Pin	1	S28078	S28078

Repair Parts – Model B56514S

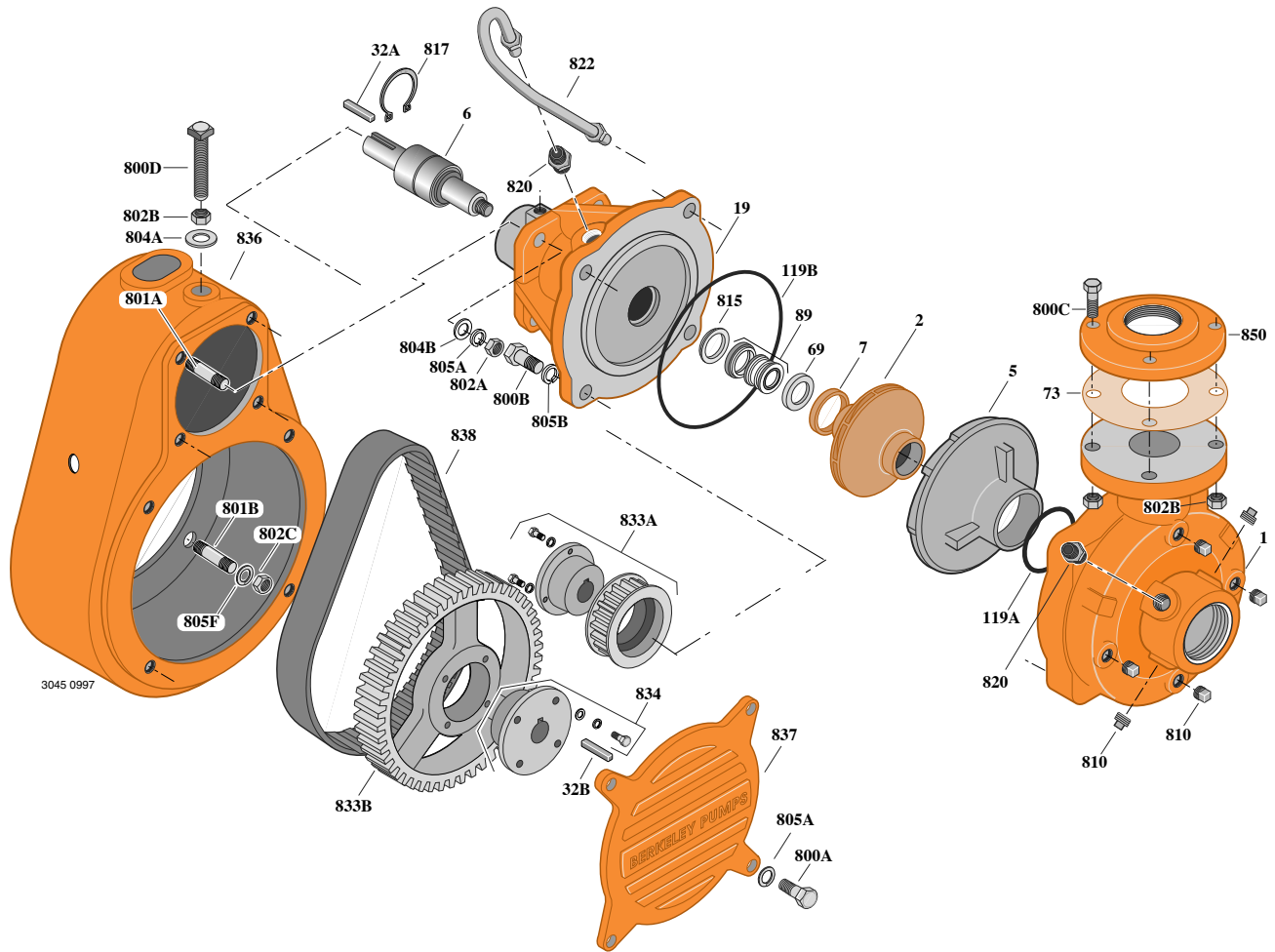

Item No.	Part Description	Part Number
1	Case, Volute	L03030
2	Impeller	H05527
5	Diffuser	L07986
6	Shaft and Bearing Assembly	S11862
7	Ring, Wear	M10891
19	Housing, Bearing	M04520
32A	Key, 3/16 x 1"	S24151
32B	Key, 1/4" x 2"	S24172
69	Washer, Impeller	S15051
73	Gasket, Flange	S10361
89	Seal, Mechanical Shaft	S22380
119A	Quadring	S13933
119B	O-Ring	S13932
800A	Capscrew, 3/8 - 16 x 1" (5 Req.)	S26826
800B	Capscrew, 1/2 - 13 x 1-1/4" (4 Req.)	S26914
800C	Capscrew, 1/2 - 13 x 2" (4 Req.)	S26920
800D	Screw, Set, 1/2 - 13 x 3"	S32407
801A	Stud 3/8-16 x 1-3/8 (4 Req.)	S09942
801 B	Stud 7/16 - 14 x 1-1/2 (4 Req.)	S24002
802A	Nut, Hex, 3/8-16 (4 Req.)	S23103
802B	Nut, Hex, 1/2-13 (5 Req.)	S23107
802C	Nut, 7/16 x 14 (4 Req.)	S23105

Item No.	Part Description	Part Number
804A	Washer, Flat 1/2 ID X 1-1/16 OD	S23052
805A	Washer, Lock, 3/8 (8 Req.)	S23076
805B	Washer, Lock, 1/2 (4 Req.)	S23091
805F	Washer, Lock, 7/16 (4 Req.)	S23077
810	Plug, Pipe, 1/4 NPT (7 Req.)	S23715
815	Ring, Seal Retaining	S11894
817	Ring, Retaining, Internal	S23022
820	Connector, Tubing (2 Req.)	S24017
822	Tubing, 3/8"	S17553
833A	Sprocket, Timing Belt, Small (Includes Taper Bushing)	S11895
833B	Sprocket, Timing Belt, Large Taper Bushing)(w/o Bushing)	S11901
834	Bushing, Split Taper (for Key No. 833B)	S31420
836	Case, Drive	H03759
837	Cover, Drive Case	S11892
838	Timing Belt	S11902
850	Flange, Companion	S11785
	• Plate, Sound Level Warning	S19086
	• Arrestor, Spark, Assembly	S35596
	• Engine (B & S 18 HP)	S31449

• Not Illustrated

Repair Parts – Models B54728S, B07536S

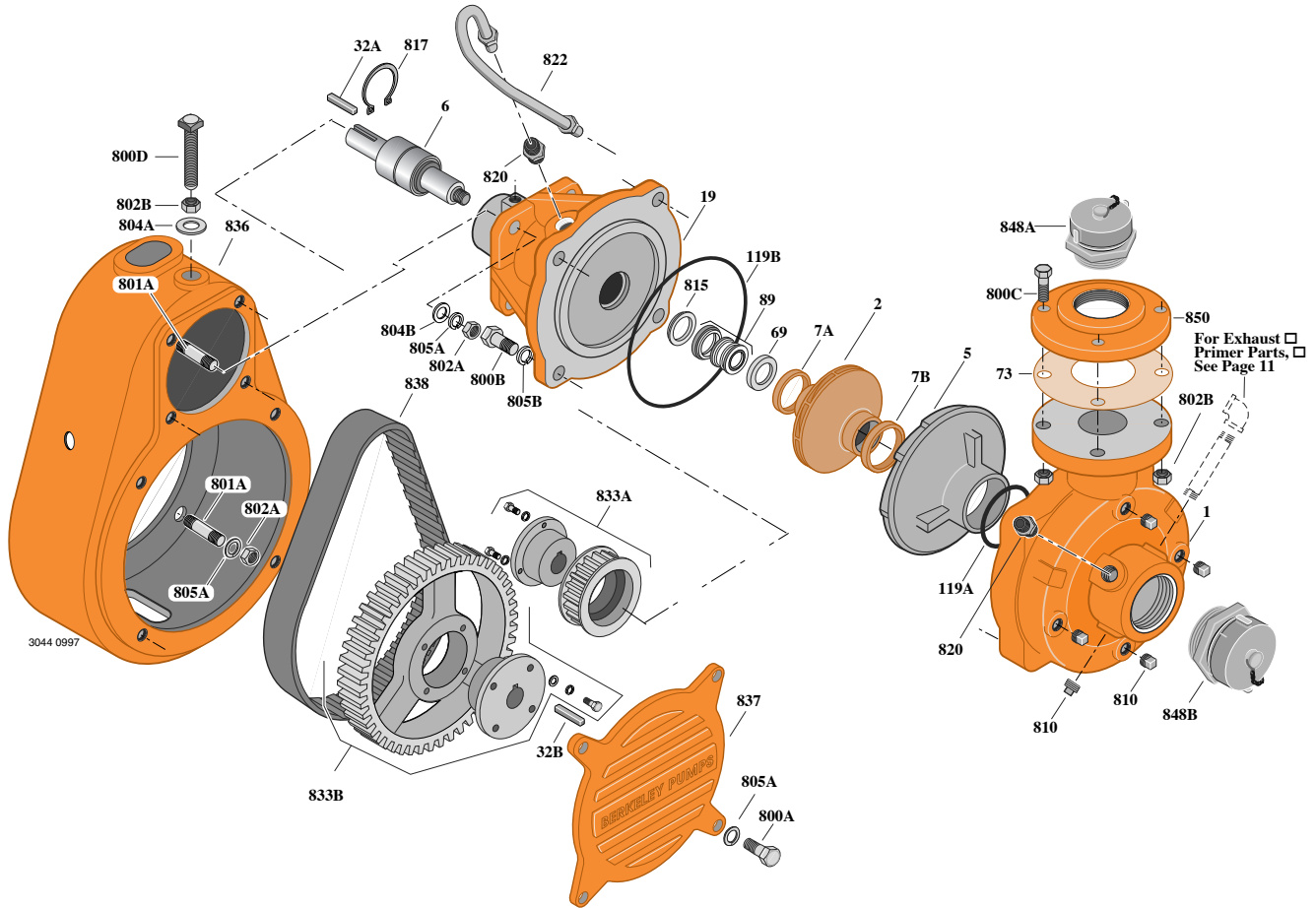

Item No.	Part Description	Part Number
1	Case, Volute	L03030
2	Impeller	H05526
5	Diffuser	L07986
6	Shaft and Bearing Assembly	S11862
7A	Ring, Wear	M10911
7B	Ring, Wear	M10891
19	Housing, Bearing	M04520
32A	Key, 3/16 x 1"	S24151
32B	Key, 1/4" x 2"	S24172
67	Spacer, Impeller	S00512
73	Gasket, Flange	S10361
89	Seal, Mechanical Shaft	S22380
119A	Quadring	S13933
119B	O-Ring	S13932
800A	Capscrew, 3/8 - 16 x 1" (4 Req.)	S26826
800B	Capscrew, 1/2 - 13 x 1-1/4" (4 Req.)	S26914
800C	Capscrew, 1/2 - 13 x 2" (4 Req.)	S26920
800D	Screw, Set, 1/2 - 13 x 3"	S32407
801	Stud, 3/8 - 16 x 1-3/8" (8 Req.)	S09942
802A	Nut, Hex, 3/8-16 (8 Req.)	S23103
802B	Nut, Hex, 1/2-13 (4 Req.)	S23107
804A	Washer, Flat 1/2 ID X 1-1/16 OD	S23052
805A	Washer, Lock, 3/8 (12 Req.)	S23076
805E	Washer, Lock, 1/2 (4 Req.)	S23091

Item No.	Part Description	Part Number
810	Plug, Pipe, 1/4 NPT (6 or 7 Req.)	S23715
815	Ring, Seal Retaining	S11894
817	Ring, Retaining, Internal	S23022
820	Connector, Tubing (2 Req.)	S24017
822	Tubing, 3/8"	S17553
833A	Sprocket, Timing Belt, Small (w/Bushing)	S12694
833B	Sprocket, Timing Belt, Large (w/ Bushing)	S12692
836	Case, Drive	L05397
837	Cover, Drive Case	M04689
838	Timing Belt	S12691
848A	Nipple, Hose, Hex 1-1/2"NPT x 1-1/2"-9NH (Model B07536S Only)	M05666
848B	Nipple, Hose, Hex, Increasing, 2" NPT x 1-1/2"-9 NH (Model B07536S Only)	M05668
0850	Flange, Companion	S11785
•	Engine (B & S 11 HP)	S19836
•	Primer and Spark Arrester (B07536S Only) See Page 9	B06160
•	For Exhaust Primer Parts, See Page 11	S19086
•	Plate, Sound Level Warning	S19086

• Not Illustrated

Repair Parts – Models B06162S, B06172S

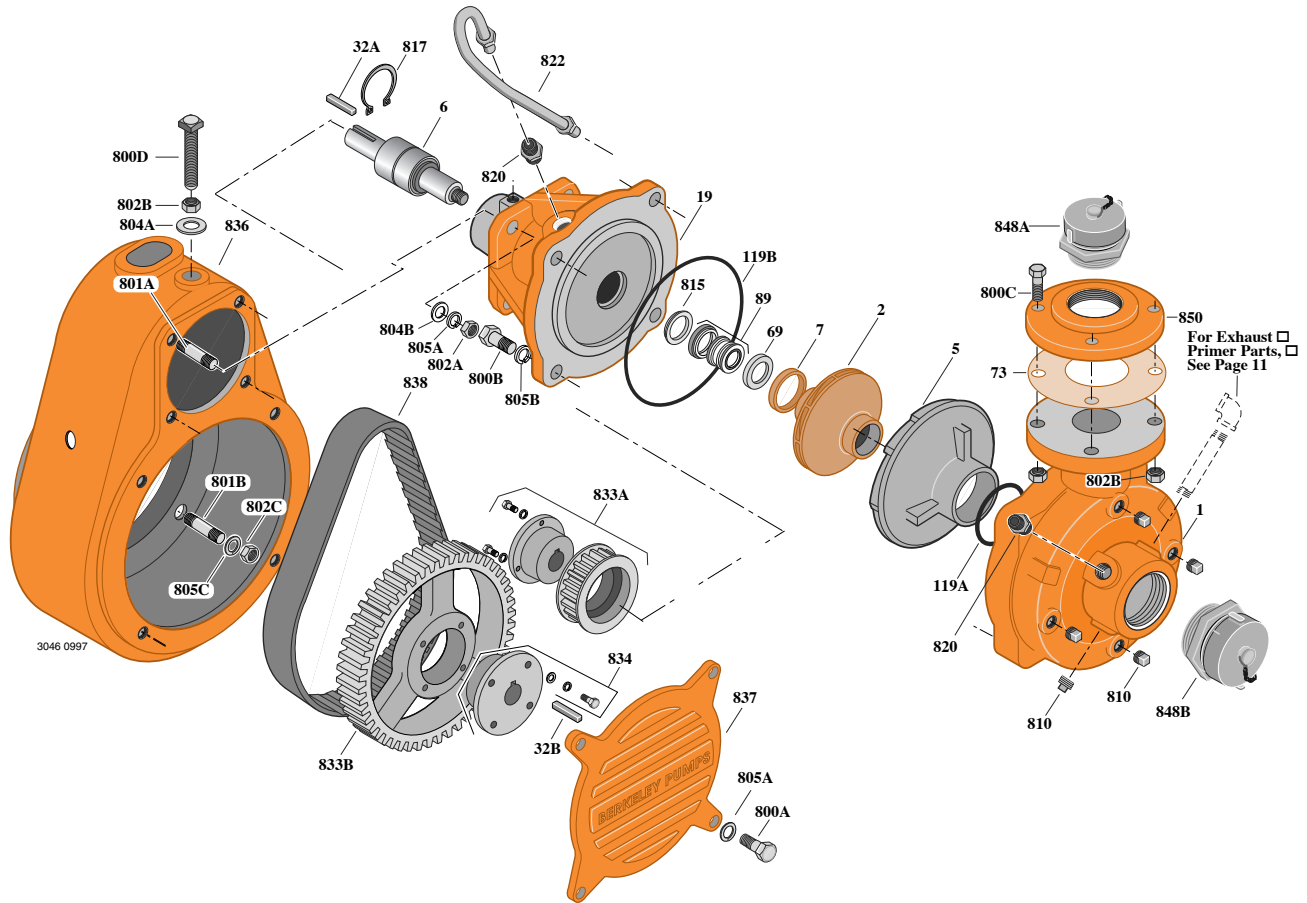

Item No.	Part Description	Part Number
1	Case, Volute	L03030
2	Impeller	H05528
5	Diffuser	L07986
6	Shaft and Bearing Assembly	S11862
7	Ring, Wear	M10891
19	Housing, Bearing	M04520
32A	Key, 3/16 x 1"	S24151
32B	Key, 3/8" x 2"	S24189
69	Washer, Impeller	S15051
73	Gasket, Flange	S10361
89	Seal, Mechanical Shaft	S22380
119A	Quadring	S13933
119B	O-Ring	S13932
800A	Capscrew, 3/8 - 16 x 1" (4 Req.)	S26826
800B	Capscrew, 1/2 - 13 x 1-1/4" (4 Req.)	S26914
800C	Capscrew, 1/2 - 13 x 2" (4 Req.)	S26920
800D	Screw, Set, 1/2 - 13 x 3"	S32407
801A	Stud, 3/8 - 16 x 1-3/8" (4 Req.)	S09942
801B	Stud, 7/16 - 14 x 2-1/2" (4 Req.)	S24006
802A	Nut, Hex, 3/8-16 (4 Req.)	S23103
802B	Nut, Hex, 1/2-13 (5 Req.)	S23107
802C	Nut, 7/16 - 14 (4 Req.)	S23105
804A	Washer, Flat 1/2 ID X 1-1/16 OD	S23052
805A	Washer, Lock, 3/8 (8 Req.)	S23076
805B	Washer, Lock, 1/2 (4 Req.)	S23091

Item No.	Part Description	Part Number
805C	Washer, Lock 7/16 (4 Req.)	S23077
810	Plug, Pipe, 1/4 NPT (6 or 7 Req.)	S23715
815	Ring, Seal Retaining	S11894
817	Ring, Retaining, Internal	S23022
820	Connector, Tubing (2 Req.)	S24017
822	Tubing, 3/8"	S17553
833A	Sprocket, Timing Belt	S11895
833B	Sprocket, Timing Belt	S11901
834	Bushing, Split Taper (for Key No. 833B)	S35598
836	Case, Drive	H01879
837	Cover, Drive Case	S11892
838	Timing Belt	S11902
848A	Nipple, Hose, Hex 1-1/2" NPT x 1-1/2"-9 NH (Model B06172S Only)	M05666
848B	Nipple, Hose, Hex, Increasing, 2" NPT x 2-1/2"-7-1/2 NH (Model B06172S Only)	M05668
850	Flange, Companion • Primer and Spark Arrester (B07536S Only) See Page 9 • For Primer/Spark Arrestor Parts	S11785
	• Plate, Sound Level Warning	S19086
	• Engine (Wisconsin 18 HP)	S28668

• Not Illustrated

Repair Parts – Model B58603S

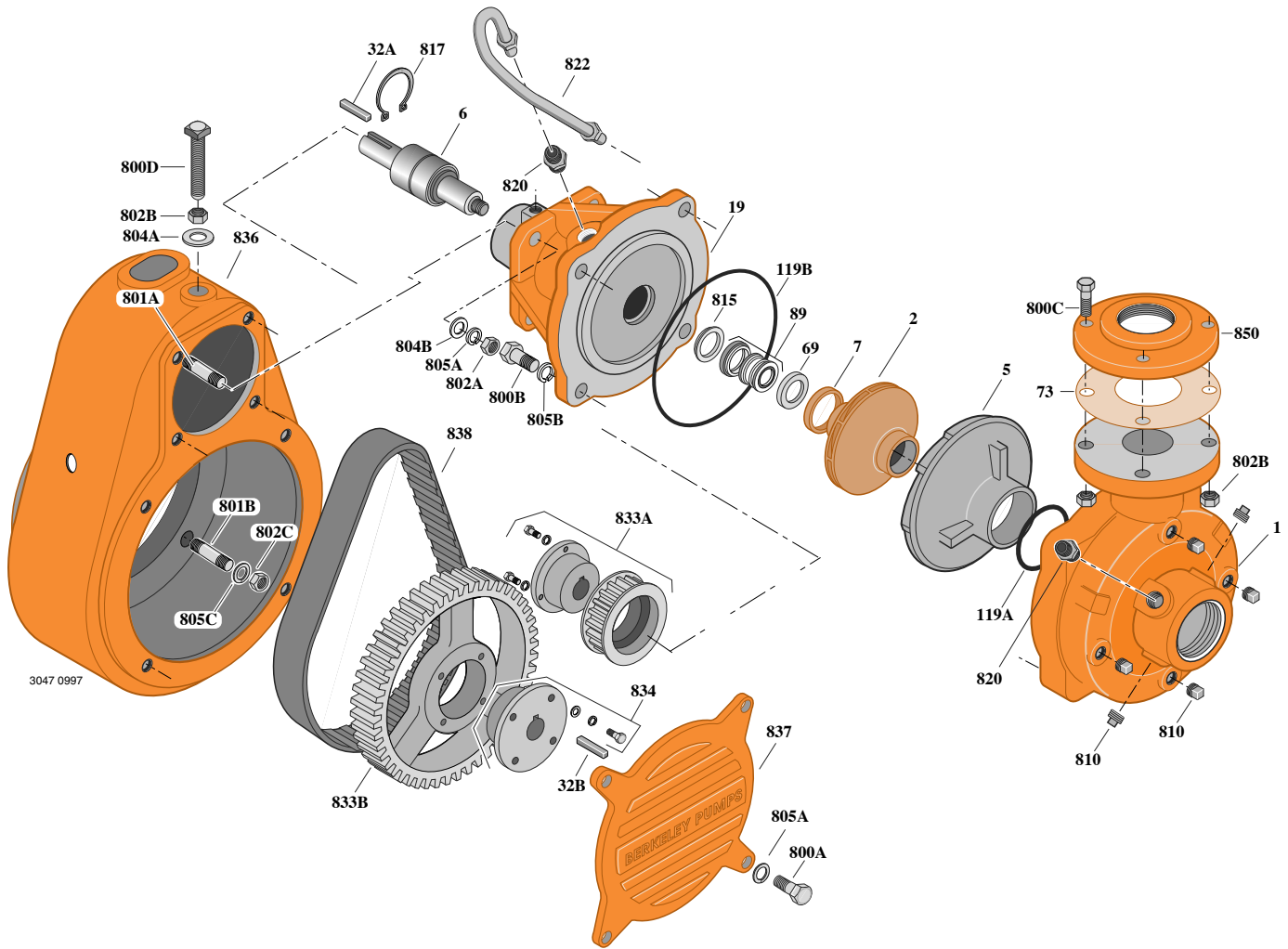

Item No.	Part Description	Part Number
1	Case, Volute	L03030
2	Impeller	H05528
5	Diffuser	L07986
6	Shaft and Bearing Assembly	S11862
7	Ring, Wear	M10891
19	Housing, Bearing	M04520
32A	Key, 3/16 x 1"	S24151
32B	Key, 3/8" x 2"	S24189
69	Washer, Impeller	S15051
73	Gasket, Flange	S10361
89	Seal, Mechanical Shaft	S22380
119A	Quadring	S13933
119B	O-Ring	S13932
800A	Capscrew, 3/8 - 16 x 1" (5 Req.)	S26826
800B	Capscrew, 1/2 - 13 x 1-1/4" (4 Req.)	S26914
800C	Capscrew, 1/2 - 13 x 2" (4 Req.)	S26920
800D	Screw, Set, 1/2 - 13 x 3"	S32407
801A	Stud, 3/8 - 16 x 1-3/8" (4 Req.)	S09942
801B	Stud, 7/16 - 14 x 2-1/2" (4 Req.)	S24006
802A	Nut, Hex, 3/8-16 (4 Req.)	S23103
802B	Nut, Hex, 1/2-13 (5 Req.)	S23107

Item No.	Part Description	Part Number
802C	Nut, 7/16 - 14 (4 Req.)	S23105
804A	Washer, Flat 1/2 ID X 1-1/16 OD	S23052
805A	Washer, Lock, 3/8 (8 Req.)	S23076
805B	Washer, Lock, 1/2 (4 Req.)	S23091
805C	Washer, Lock, 7/16 (4 Req.)	S23077
810	Plug, Pipe, 1/4 NPT (6 Req.)	S23715
815	Ring, Seal Retaining	S11894
817	Ring, Retaining, Internal	S23022
820	Connector, Tubing (2 Req.)	S24017
822	Tubing, 3/8"	S17553
833A	Sprocket, Timing Belt	S11895
833B	Sprocket, Timing Belt	S11901
834	Bushing, Split Taper (for Key No. 833B)	S35598
836	Case, Drive	H01879
837	Cover, Drive Case	S11892
838	Timing Belt	S11902
850	Flange, Companion	S11785
	• Plate, Sound Level Warning	S19086
	• Engine (Lombardini 26 HP Diesel)	S32859

• Not Illustrated

