

self-priming air-cooled engine drive



Lightweight, corrosion resistant, engineered composite pump construction make this engine-driven pump extremely versatile for applications where electrical power is not available.

Powered by a powerful 5-1/2 HP, PowerPro 4-cycle gasoline engine, rated for continuous-duty, equipped with professional-grade features like an automatic low-oil safety cut, manual throttle, choke and shut-off controls.

Securely mounted within a rugged steel framed rollcage, reinforced with steel cross-members, coated for corrosion resistance, equipped with noise dampening, non-slip rubber feet.

Suction lift capability of 25 feet.

ORDERING INFORMATION

Catalog Number	HP	Description	Pipe Tapping Sizes		Approx. Wt. Lbs./Kg.
			Suction	Discharge	
EDP55RV	5-1/2	Engine-driven pump w/roll cage	2" NPT	2" NPT	46/20.9

ACCESSORIES

Catalog Number	Description	Approx. Wt. Lbs./Kg.
FP2735	2" x 15' Suction Hose Kit	15/6.8
FP2731	2" x 25' Discharge Hose Kit	6/2.7



**FP2735
Suction
Hose Kit**



**FP2731
Discharge
Hose Kit**

APPLICATIONS

- Water Transfer and Supply
- Sprinkler Turf Irrigation
- Dewatering
- Fire Protection
- Agriculture, Light Commercial and Marine

SPECIFICATIONS

Body – Reinforced corrosion resistant Thermoplastic

Impeller – Polymer

Diffuser – Reinforced corrosion resistant Thermoplastic

Seals – Viton mechanical

O-rings – Viton

Check Valve – Viton

Roll Cage – Coated steel frame with cross member and stay-in-place (no-slip) rubber feet

Engine – 5-1/2 HP PowerPro

Dimensions – 21"H x 17"D x 21"L

Fasteners – 300 Grade stainless steel

FEATURES

Rugged Light-Weight Design

Corrosion Resistant Composite Pump Construction

Chemical Resistant Viton Seals, O-rings with Stainless Steel Fasteners

Built-in Check Valve

ACCESSORIES

Suction Hose Kit – Built-in 2" NPTF swivel fitting and 2" NPTM fitting for easy hookup; coil-reinforced wall prevents collapse; includes aluminum suction screen to prevent debris from reaching pump

Discharge Hose Kit – Built-in 2" NPTF swivel fitting and 2" NPTM fitting for easy hookup; collapsible for easy roll-up and storage; reinforced wall adds durability

In order to provide the best products possible, specifications are subject to change.



composite engine-driven self-priming pump

PUMP PERFORMANCE

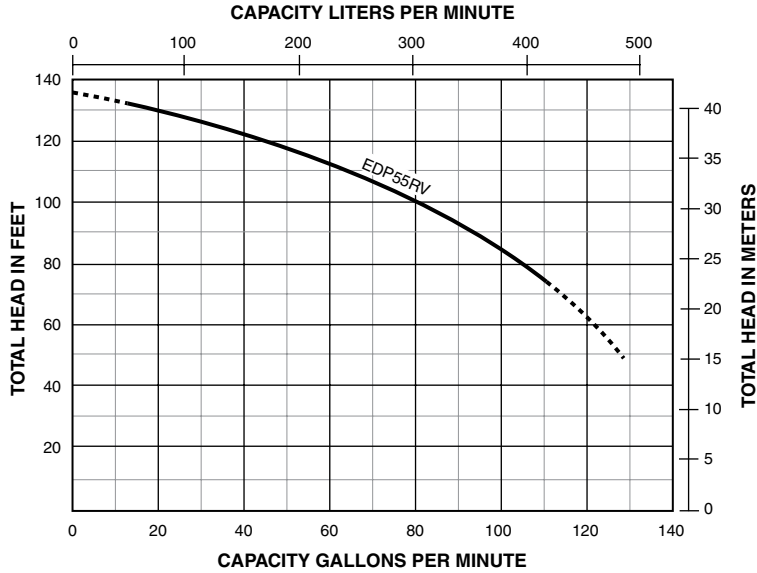

OUTLINE DIMENSIONS

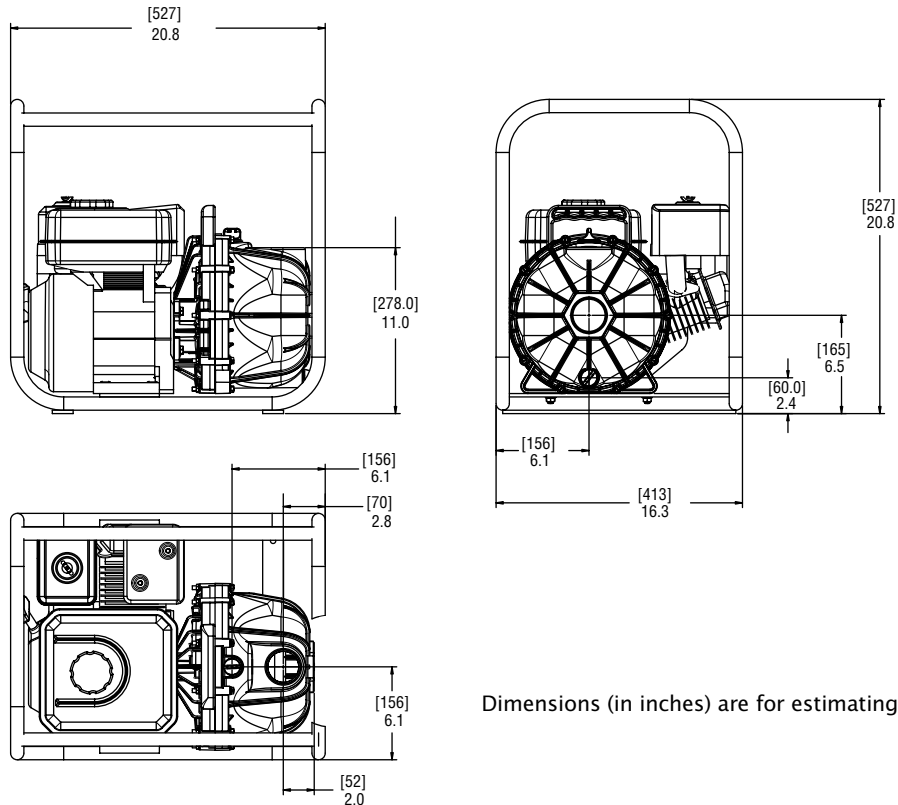

Dimensions (in inches) are for estimating purposes only.

