



Product information presented here reflects conditions at time of publication. Consult factory regarding discrepancies or inconsistencies.

MAIL TO: P.O. BOX 16347 • Louisville, KY 40256-0347  
SHIP TO: 3649 Cane Run Road • Louisville, KY 40211-1961  
(502) 778-2731 • 1 (800) 928-PUMP • FAX (502) 774-3624

visit our web site:  
[www.zoeller.com](http://www.zoeller.com)

## COMPARE THESE FEATURES:

- Casting - All cast iron class 25-30 25000# tensile strength.
- Motor - 2 HP (404), 3 HP (405) - 60 Hz, 1725 RPM oil-filled, hermetically sealed, automatic reset thermal overload protected (1 PH).
- Upper sleeve bearing and lower ball bearing running in bath of oil.
- UL Listed cord - 20 ft. - 3-wire neoprene cord and plug. Longer cords available in lengths of 25-35-50 feet.
- Impeller - Non-clogging vortex.
- Mechanical shaft seal - Carbon and ceramic rotary face seal, with stainless steel wetted parts.
- Hardware - Stainless steel screws, bolts, washers, lifting bracket.
- Square ring and gasket - Neoprene.
- Temperature to 130°F (54°C), 120°F (49°C) for WD405.
- Variable level controls available.
- 4" horizontal flanged discharge - Standard ANSI flange.
- Passes 3" spherical solids.
- Corrosion resistant powder coated epoxy finish.

## MODEL 4404/4405 DOUBLE SEAL PUMPS (nonauto)

- Protects motor from seal leaks.
- Improved seal lubrication.
- Helps eliminate seal and bearing damage from dry runs.
- Major width 16 1/8". Height 27 1/2".

## APPLICATIONS

- High capacity water removal - parking lots - low flood areas - water transfer.
- To meet 3" intake, 4" discharge code requirements on some sewage applications.
- Retrofit on existing sewage installations.
- New installations.

## GUIDE RAIL SYSTEMS

- 4" pipe flange fittings.
- P/N 39-0016.

### Includes:

1. Cast iron discharge elbow.
2. Stainless steel lower guides.
3. Cast iron mounting plate.
4. Stainless steel upper guide rail bracket.
5. Optional intermediate stabilizer for systems over 15' deep.  
P/N 39-0013 carbon steel.  
P/N 39-0014 stainless steel
6. Stainless steel guide brackets for pump mounting plate.
7. Buna N gasket for mounting plate.
8. Stainless steel bolts and lock washers.

### Featuring:

- Automatic engagement.
- Easy disengagement.
- Class 30 cast iron fittings.

## 404 - 405 Single Seal Series 4404 - 4405 Double Seal Series

(For Pump Prefix Identification see News & Views 0052)

# "WASTE-MATE"

SUBMERSIBLE  
**SEWAGE**  
OR DEWATERING PUMP



SSPMA  
MEMBER

SUMP  
AND SEWAGE  
PUMP MFRS. ASSN.



QUALITY MADE  
Pump Co.  
U.S. CRAFTSMEN

**SINGLE  
SEAL  
PUMP**



**POWDER  
COATED  
TOUGH™**



**DOUBLE  
SEAL  
PUMP**





CSA US  
(Tested to UL778 and  
CSA22.2 108 Standards)

**MODELS AVAILABLE**

- Automatic with float switch (WD models only)
- Nonautomatic

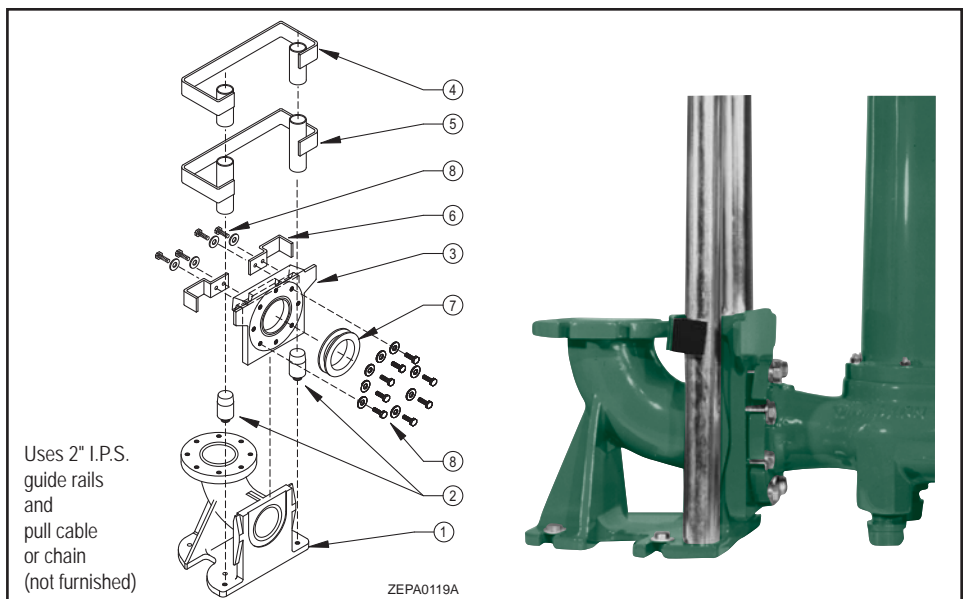

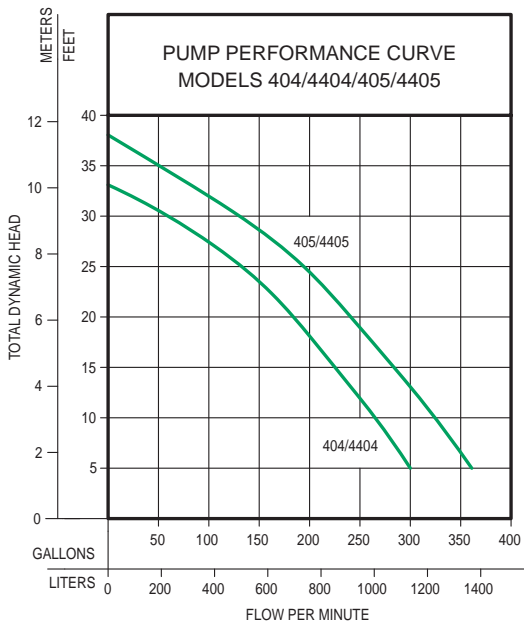

MODEL		404/4404		405/4405	
Feet	Meters	Gal.	Liters	Gal.	Liters
5	1.5	300	1136	361	1367
10	3.0	265	1003	326	1234
15	4.6	224	848	284	1075
20	6.1	184	698	241	912
25	7.6	134	503	197	746
30	9.1	60	227	134	507
35	10.7	--	--	50	189
Shut-off Head:		33 ft.(10.1m)		38 ft.(11.6m)	

012116

**Single Seal Design**  
Weight 136 lbs.

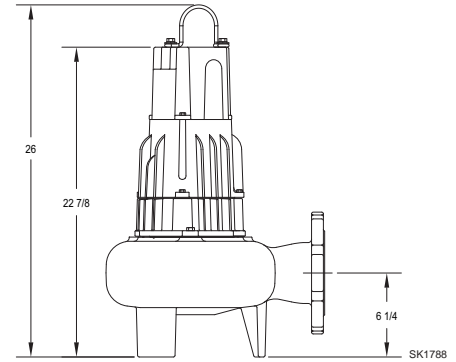
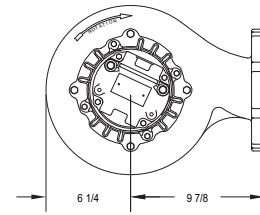

## CONSULT FACTORY FOR SPECIAL APPLICATIONS

- Three phase pumps available in 200/208V, 230V, 460V, or 575V.
- Electrical alternators, for duplex systems.
- Mechanical alternators, for \*duplex systems.
- Simplex control panels are available.
- Variable level float switches are available for controlling single and three phase systems included with WD405 model pumps.
- Double piggyback float switches are available for variable level long cycle controls.
- Long cords available in lengths of 25-35-50 feet.
- Simplex and duplex basins are available.

\*With or without high-water alarm function.

### Standard Models

404/4404 Series - 20 ft. cord - 2 HP						Control Selection		Listing
Single Seal	Double Seal	Volts	PH	Mode	Amp	Simplex	Duplex	CSA
* E404	* E4404	230	1	Nonautomatic	12.9	1 or 2	3	Y
** WD404	** WD4404	230	1	Automatic	12.9	**	---	Y
I404	I4404	200	1	Nonautomatic	14.4	2	3	Y
J404	J4404	200	3	Nonautomatic	13.8	2	3	Y
F404	F4404	230	3	Nonautomatic	10.5	2	3	Y
G404	G4404	460	3	Nonautomatic	5.2	2	3	Y
BA404	BA4404	575	3	Nonautomatic	4.1	2	3	Y

405/4405 Series - 20 ft. cord - 3 HP						Control Selection		Listing
Single Seal	Double Seal	Volts	PH	Mode	Amp	Simplex	Duplex	CSA
* E405	* E4405	230	1	Nonautomatic	19.0	1 or 2	3	Y
** WD405	** WD4405	230	1	Automatic	19.0	**	---	Y
I405	I4405	200	1	Nonautomatic	20.2	2	3	Y
J405	J4405	200	3	Nonautomatic	14.8	2	3	Y
F405	F4405	230	3	Nonautomatic	12.2	2	3	Y
G405	G4405	460	3	Nonautomatic	6.1	2	3	Y
BA405	BA4405	575	3	Nonautomatic	4.8	2	3	Y

\* Molded Plug  
\*\* Includes variable level float switch.

For information on additional Zoeller products refer to catalog on Simplex controls, FM1596; Piggyback Variable Level Switches, FM0477; Electrical Alternator, FM0486; Mechanical Alternator, FM0495; Alarm Package, FM0513; Sump/Sewage Basins, FM0487; and Simplex Control Box, FM0732; Rail Systems, FM0787; and Junction Boxes, FM1597.

**Double Seal Design**  
Weight 143 lbs.

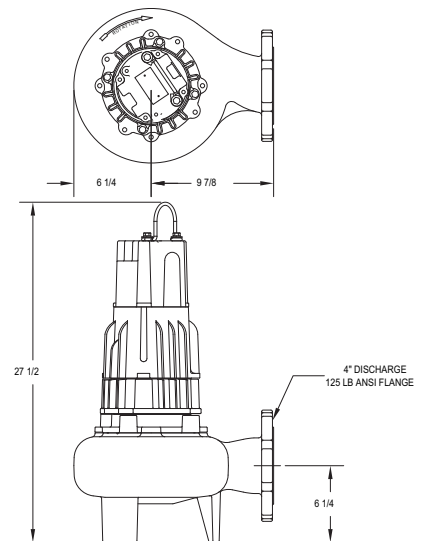

SK1787

### SELECTION GUIDE:

1. For automatic use single piggyback variable level float switch or double piggyback variable level float switch. Refer to FM0477.
2. See FM1228 for correct model of simplex control panel.
3. See FM0712 for correct model of duplex control panel.

20 amp outlet 10-0060, must be used with Model E405/4405 and WD405/4405.

**CAUTION**

All installation of controls, protection devices and wiring should be done by a qualified licensed electrician. All electrical and safety codes should be followed including the most recent National Electrical Code (NEC) and the Occupational Safety and Health Act (OSHA).

## RESERVE POWERED DESIGN

For unusual conditions a reserve safety factor is engineered into the design of every Zoeller pump.