

PREPACKAGED AND JOB READY SYSTEMS

SIMPLEX		INDOOR	DUPLEX	
REQ.			REQ.	
1 Grinder	P/N _____ (A)		2 Grinders	P/N _____ (A)
1 Simplex Control Panel	P/N _____ (B)		1 Duplex Control Panel	P/N _____ (B)
1 Variable Level Fl. Sw. Assm.	P/N _____ (C)		1 Variable Level Fl. Sw. Assm.	P/N _____ (C)
1 Basin, Cover and Hardware	P/N _____ (F)		1 Basin, Cover and Hardware	P/N _____ (F)

SIMPLEX		OUTDOOR	DUPLEX	
REQ.		REQ.		
1 Grinder	P/N _____ (A)	2 Grinders	P/N _____ (A)	
1 Simplex Control Panel	P/N _____ (B)	1 Duplex Control Panel	P/N _____ (B)	
1 Variable Level Fl. Sw. Assm.	P/N _____ (C)	1 Variable Level Fl. Sw. Assm.	P/N _____ (C)	
1 J-Box	P/N _____ (E)	1 J-Box	P/N _____ (E)	
1 Basin, Cover and Rail System	P/N _____ (G)	1 Basin, Cover and Rail System	P/N _____ (G)	

FIELD MOUNT SYSTEMS

SIMPLEX	
REQ.	
1 Grinder	P/N _____ (A)
1 Simplex Control Panel	P/N _____ (B)
1 Variable Level Fl. Sw. Assm.	P/N _____ (C)
1 Junction Box	P/N _____ (E)
1 Rail System	P/N _____ (H)
1 Angle Arm/Intermediate Bracket*	P/N _____ (H)
1 Pull Rod**	P/N _____ (J)
1 S.S. Lifting Cable	P/N _____ (K)
DUPLEX	
REQ.	
2 Grinders	P/N _____ (A)
1 Duplex Control Panel	P/N _____ (B)
1 Variable Level Fl. Sw. Assm.	P/N _____ (C)
1 Junction Box	P/N _____ (E)
2 Rail Systems	P/N _____ (H)
2 Angle Arm/Intermediate Bracket*	P/N _____ (H)
2 Pull Rods**	P/N _____ (J)
2 S.S. Lifting Cables	P/N _____ (K)

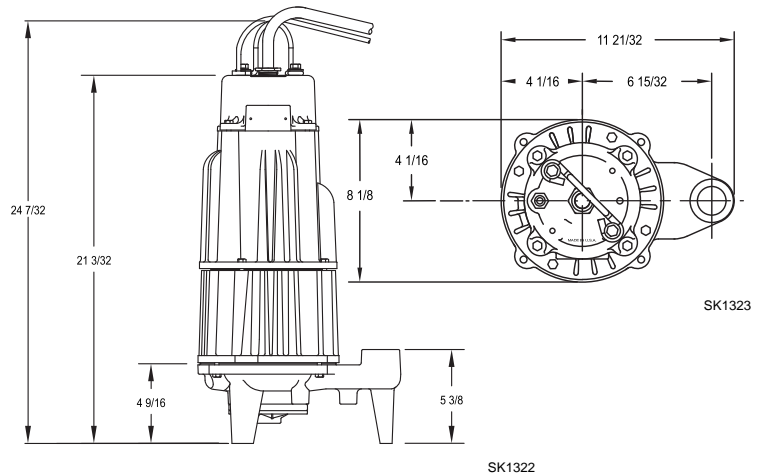

* Required for basin depths over 72" (Square Guide Rail) and over 12' (E-Z Out Rail). Allow for overhead clearances.

** For Square Guide Rail only.

Access Doors Available on Field Mount Systems - Consult Factory
 Special Basin Configurations - Consult Factory
 Junction Box Mounting & Assembly - Consult Factory

Manufacturers of . . .

"QUALITY PUMPS SINCE 1939"