

PREPACKAGED AND JOB READY SYSTEMS

INDOOR

REQ.

1 810 or 815 Grinder	P/N _____ (A)
1 Alarm Panel	P/N _____ (B)
1 Piggyback Pump Switch	P/N _____ (C)
1 Weight for Alarm Float	P/N _____ (C)
1 Basin, Cover and Hardware	P/N _____ (E)

OUTDOOR

REQ.

1 810 or 815 Grinder	P/N _____ (A)
1 Control Panel/Alarm System	P/N _____ (B)
1 Piggyback Pump Switch	P/N _____ (C)
1 Control Switch (if required)	P/N _____ (C)
1 Junction Box (if required)	P/N _____ (D)
1 Package Basin Assembly	P/N _____ (E)

FIELD MOUNT SYSTEMS

SIMPLEX

REQ.

1 810 or 815 Grinder	P/N _____ (A)
1 Control Panel / Alarm System	P/N _____ (B)
1 Piggyback Pump Switch	P/N _____ (C)
1 Control Switch (if required)	P/N _____ (C)
1 Weight for Alarm Float (if required)	P/N _____ (C)
1 Junction Box (Optional)	P/N _____ (D)
1 Optional Accessories	P/N _____ (F)
	P/N _____ (F)
	P/N _____ (F)

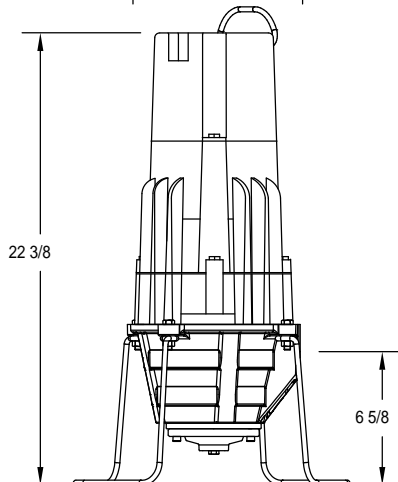
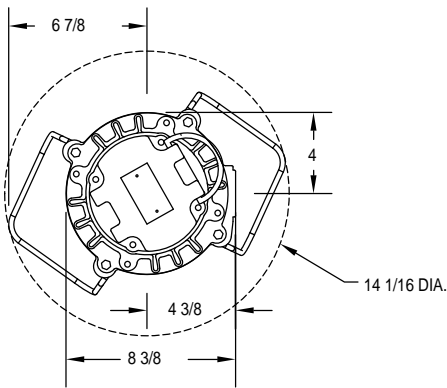
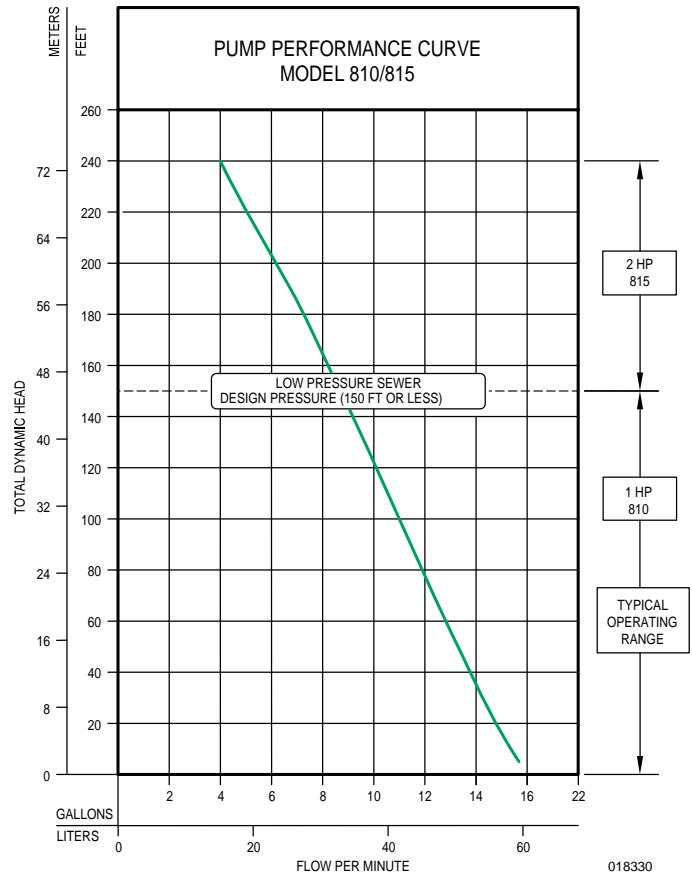

SK2533

"922" Packaged Systems

Refer to FM2370 for Packaged Fiberglass or Poly-ribbed Basin Assemblies for the models 810 and 815.

Manufacturers of . . . *QUALITY PUMPS SINCE 1939*